

PSB-CD/FD01

Installation Guide

The PSB-CD/FD01 CD-ROM/FD drive unit is made by Pro-face for use with its PS-2000B Series Built-in computer (hereafter referred as the "PS-B") units.

Corresponding Product : PS-2000B Series Units

All product names used in this document are the trademarks of their respective manufacturers.

Pro-face : Digital Electronics Corporation (in Japan and other countries)

WARNINGS

- Be sure to check that the PS-B's power is disconnected before installing the unit, in order to prevent an electrical shock.
- Do not attempt to modify or open the PSB-CD/FD01, since it can cause a shock or fire.
- When installing the PSB-CD/FD01, be sure to read this guide's "3. Installation" section's information completely to insure that the unit is correctly installed.

To prevent this unit from malfunctioning :

- Since the PSB-CD/FD01 is a precision instrument, be sure that it is neither hit by nor pressed strongly against another object.
- Be sure that water, liquids, or metal particles are not allowed to contact or enter this unit. Any of these may cause either a breakdown or an electrical shock.
- Do not place or store this unit in a location where there is direct sunlight, excessive heat, dust or vibration.
- Do not store or operate this unit in a location where there is direct sunlight, excessive heat, dust or vibration.
- Do not use the PSB-CD/FD01 in locations where corrosive gasses are present.
- To prevent damage to file data, be sure to shut down the PS-B unit's OS before turning OFF the main power.

Package Contents

Please check that the following items are all included in your package.

■ **PSB-CD/FD01 (1)**

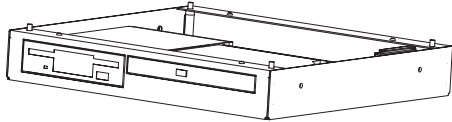

■ **Installation Guide (1)**
(PSB-CD/FD01)
(this guide)

**Installation
Guide**

Pro-face has taken the utmost care to insure the quality of this product when it was shipped, however, should for any reason problems or damage have occurred during shipping, please contact your Pro-face representative immediately for service.

1 Hardware Specifications

■ **Performance**

◆ **CD-ROM Drive**

Random Access Seek	140ms (typ.)
Data Transfer Speed	16.7MB/sec (Max.)
Disk Speed	4,280rpm(typ.)
Power Consumption	At startup : 0.9A (typ.) During Random Access : 0.8A (typ.) During wait : 0.5A (typ.)

◆ **FD Drive**

Operation Mode	2MB mode record/write	1MB mode record/write
Disc Type (3.5 inch)	High density (2HD)	Double density (2DD)
Unformatted Data Capacity	2MB	1MB
Data Transfer Speed	500K bits/second	250K bits/second
Disc Rotation Speed	300 rpm	
Track Density	135 tpi	
Track-track Seek Speed	3 ms	
Power Consumption	At startup : 0.7A (typ.) At read/write : 0.3A (typ.) During wait : 0.01A (typ.)	
Reliability (MTBF)	30,000 hours	

■ **Environmental**

Ambient Operating Temperature	5°C to 50°C
Ambient Storage Temperature	-10°C to 65°C
Ambient Humidity	10%RH to 85%RH (no condensation) (Wet bulb temperature: 29°C or less)
Air Purity (Dust)	0.1mg/m ³ or less (non-conductive levels)
Atmosphere	free of corrosive gases
Vibration Resistance	2.94m/s ² (10Hz to 25Hz) X, Y, Z directions for 30 minutes
Shock Resistance	58.8m/s ² (1ms, Half-sine shock pulse)



The environment specifications given here are for a unit installed in a PS-B.

■ **Structural**

Weight	Approx. 2,000 g
Dimensions	W41 mm [1.61 in.] x H265 mm [10.43 in.] x D260 mm [10.24 in.]

2 Installation

Use the following steps to install the PSB-CD/FD01 in the PS-B unit.



WARNING

Shock Danger! Be sure to disconnect the PS-B unit's power cord from its power supply prior to installing the PSB-CD/FD01.

Cover

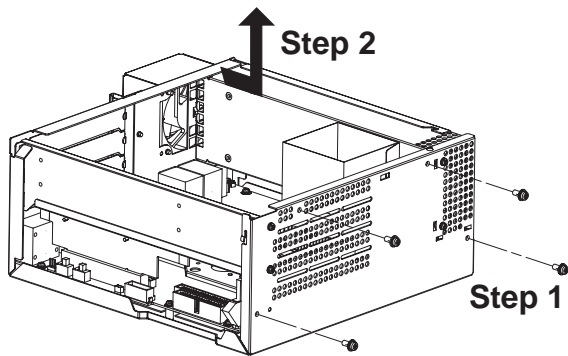
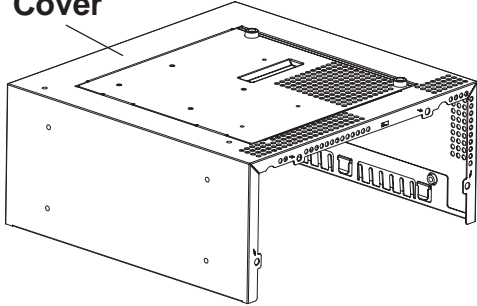

- 1) Lay the PS-B unit on its side and unscrew the four (4) cover attachment screws.

- 2) Slide the cover horizontally in the direction shown by the arrow (see diagram) and lift it off of the PS-B unit.

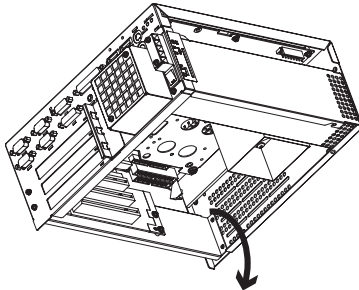

- 3) Turn the PS-B unit over and place the PSB-CD/FD01 on the bottom of the PS-B unit. (See diagram)

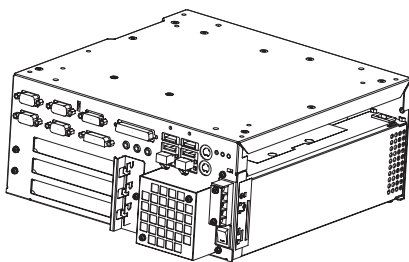

PSB-CD/FD01



Note: Inside the PSB-CD/FD01, there are four (4) cables. These cables will be connected to the PS-B unit, and must be routed through the Cable Opening on the side of the PS-B. Be sure these cables are aligned with the Cable Opening when attaching the PSB-CD/FD01 to the PS-B.

Cable Opening

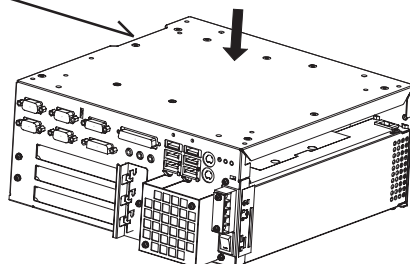

- 4) Check that all cables are routed correctly. Secure the PSB-CD/FD01 to the PS-B using the four (4) attachment screws, one for each corner of the PSB-CD/FD01's bottom face.



Note: The torque should be 0.6 to 0.8 N•m.

- 5) Turn the PS-B over to its normal orientation.

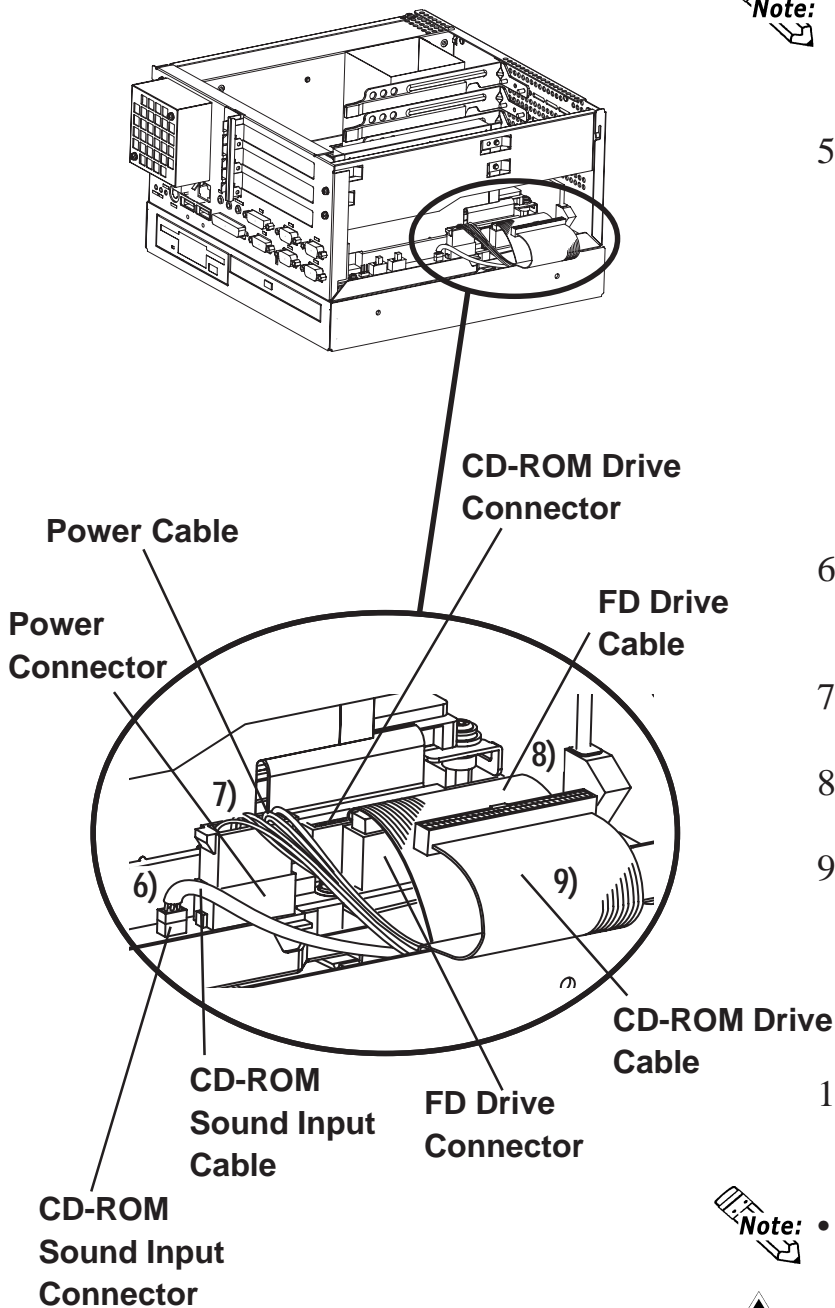

- 6) Insert the CD-ROM sound input cable into the CD-ROM sound input connector.
- 7) Insert the power cable into the power connector.
- 8) Insert the FD drive cable into the FD drive connector.
- 9) Insert the CD-ROM drive cable into the CD-ROM drive connector.

- 10) Replace the PS-B's cover and reattach the four (4) cover attachment screws.



- The torque should be 0.6 to 0.8 N•m.
- Be sure all PSB-CD/FD01 cables are inside the PS-B unit's cover.

3 Hardware Setup



- Normally, the factory default settings should be used.
- Certain BIOS screen items may differ from those shown here due to BIOS updates.



All the following explanation screens use the PS-B unit's factory settings (default settings).

- 1) Connect a keyboard to the PS-B unit.
- 2) Turn the PS-B unit's power ON.
- 3) When the welcome screen appears, press your PC's [DEL] key. The Setup utility will start. Select [Standard CMOS Features], and the following screen will appear.

Phoenix- AwardBIOS CMOS Setup Utilities		
Standard CMOS Features		
Date (mm:dd:yy):	Thu, Jan 1 2002	Item Help
Time (hh:mm:ss):	11 : 15 : 14	
▶ IDE Primary Master	[****]	Menu Level ▶ Change the day, month, year and century
▶ IDE Primary Slave	[****]	
▶ IDE Secondary Master	[CD-224E]	
▶ IDE Secondary Slave	[****]	
Drive A	[1.44M, 3.5 in.]	
Drive B	[None]	
Video	[EGA/VGA]	
Halt On	[All,But Keyboard]	
Base Memory	****K	
Externded Memory	****K	
Total Memory	****K	
↑↓→←:Move Enter:Select +/-/PU/PD:Value F10:Save ESC:Exit F1:General Help F5:Previous Values F6:Fail-Safe Defaults F7:Optimized Defaults		

- 4) Confirm that [Drive A:] is set to [1.44M, 3.5 in.] If the setting is different, place the cursor on the [Drive A:] selection item and use the [PU], [PD] or [+], [-] key to select the [1.44M, 3.5 in] setting.
- 5) Next, select the [IDE Secondary Master] menu. The following screen will appear.

Phoenix- AwardBIOS CMOS Setup Utility		Item Help
IDE Secondary Master		
IDE HDD Auto-Detection	[Press Enter]	
IDE Secondary Master	[Auto]	Menu Level ▶ ▶
Access Mode	[Auto]	To auto-detect the HDD's size, head...on this channel
Capacity	0 MB	
Cylinder	0	
Head	0	
Precomp	0	
Landing Zone	0	
Sector	0	
↑↓→←: Move Enter:Select +/-/PU/PD:Value F10:Save ESC:Exit F1:General Help F5:Previous Values F6:Fail-Safe Defaults F7:Optimized Defaults		

- 6) Confirm whether "AUTO" is selected for both [IDE Secondary Master] and [Access Mode]. If AUTO is not selected, change these settings to AUTO. If AUTO is selected in both, disk parameters will be automatically read when the PS-B is turned ON. The factory setting is AUTO and recommended for most users.
- 7) After all changes are made, press the [ESC] key and select [Save & Exit Setup] to save the settings.

Note

Please be aware that Digital Electronics Corporation shall not be held liable by the user for any damages, losses, or third party claims arising from the uses of this product.

Digital Electronics Corporation

8-2-52 Nanko Higashi, Suminoe-ku, Osaka 559-0031, Japan

URL: <http://www.pro-face.com/>