

Bus Conversion Unit Operation Instructions

Thank you for purchasing Digital's Bus Conversion Unit (GLC300-BCB11). This Bus Conversion Unit allows the attachment of GLC100 Series expansion units to GLC 300 Series units.

This manual contains an overview of the Bus Conversion Unit, as well as procedures to follow when installing this unit in the User's system. Be sure to read all this important information carefully prior to using this unit.

The GLC300 Series units, hereafter referred to as the "GLC", mentioned in this manual refer to the following model(s).

GLC300 Series

GLC300-TC41-24V

NOTE : This product is not CE marked or UL/cUL compliant. Therefore, be aware that when this unit is used in combination with a product that is CE marked and UL/cUL compliant, the marked and compliant product will lose its conformance with these standards.



Safety Precautions

This manual includes information that must be followed to ensure the correct and safe use of this product. Be sure to read both this manual and any related manuals to thoroughly understand the correct operation and functions of both the Bus Conversion Unit and the GLC.

■ Usage of Safety Icons

Throughout this manual the following icons are shown near procedures requiring special attention to safety. The information given below these icons contains essential safety information.

The following examples explain the meaning of each safety icon:

 WARNING	Indicates situations where severe bodily injury, death or major machine damage can occur.
 CAUTION	Indicates situations where slight bodily injury or machine damage can occur.

WARNING

- When attaching this unit to the GLC, make sure that the GLC's power cord is not plugged in to the main power (constant), to prevent an electric shock.
- Do not modify this unit in any way, since an electric shock or fire may occur.
- Do not use this unit in areas where flammable gas is present, since an explosion may occur.

■ To Prevent this unit from malfunctioning :

- Be sure the Bus Conversion Unit is operated in an environment that is within the unit's designated temperature range.
- Do not allow water, liquid or metallic objects to enter into the unit, since they can cause the unit to either malfunction or to create an electric shock.
- Do not operate or store this unit in an environment where it will be exposed to high temperatures.
- Do not operate or store this unit in an environment where it will be exposed to direct sunlight or excessive amounts of dust.
- Since this unit is a precision instrument, do not install it where strong impacts or vibration will occur.
- Do not operate or store this unit in an environment where it may be exposed to chemical vapors or fumes.

Package Contents

The following items are included in the Bus Conversion Unit's package. Prior to using the Bus Conversion Unit, be sure to confirm that all the items shown below are present.

■ **Bus Conversion Unit
(GLC300-BCB11)**

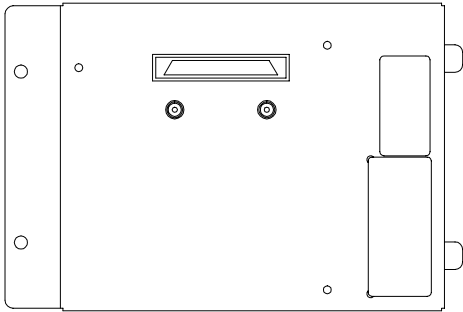

■ **Bus Conversion Unit
Operation Instructions (1)
(this document)**

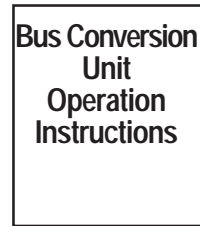

This unit has been carefully packed with special attention to quality. However, should you find anything damaged or missing, please contact your local GLC distributor immediately.

1 Dimensions

The Bus Conversion Unit's external and part dimensions are given below.

Note: • For detailed dimension information, please contact your local GLC distributor.

Unit: mm

Top View



Left Side View

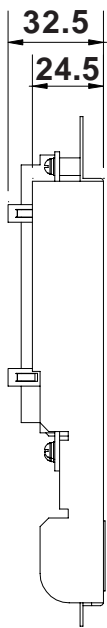

Front View

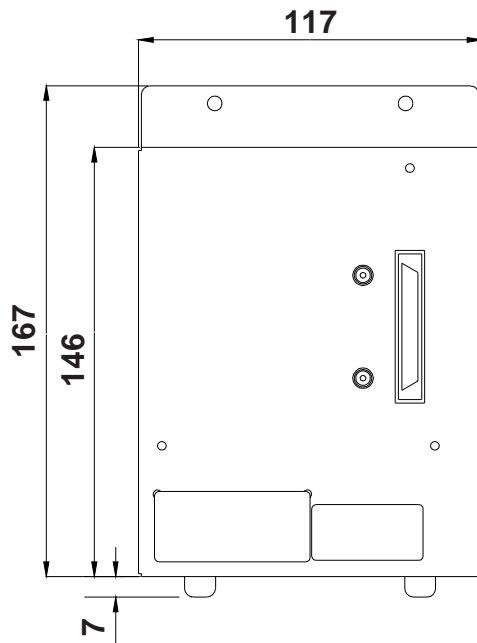

Right Side View

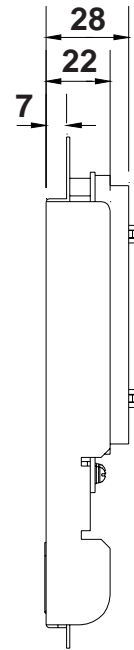

Bottom View

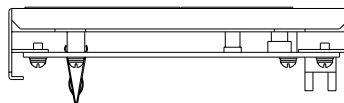

Rear View

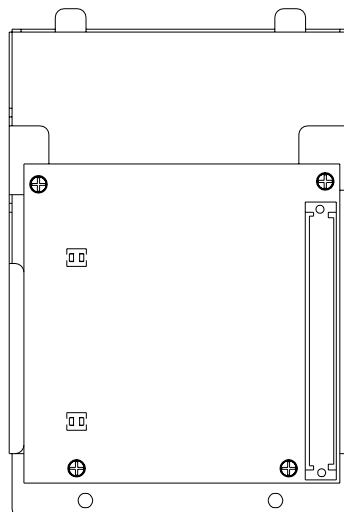

The figures below show the Bus Conversion Unit and an expansion unit (here the DIO unit is used) attached to the GLC300.

Note: • For detailed dimension information, please contact your local GLC distributor.

Unit: mm

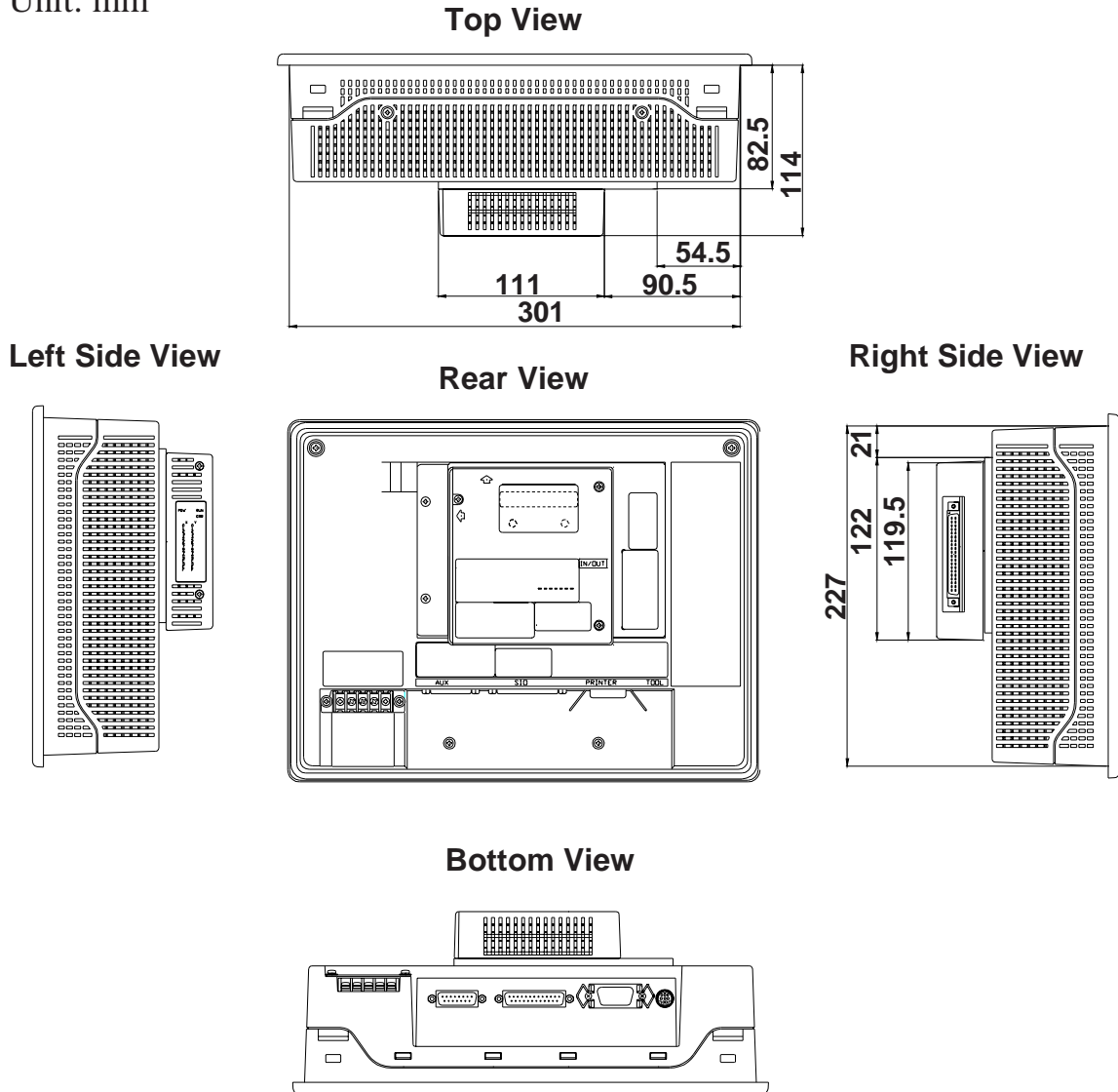

The figure below shows the Bus Conversion Unit and two expansion units (here the DIO unit is used) attached to the GLC300.

Unit: mm

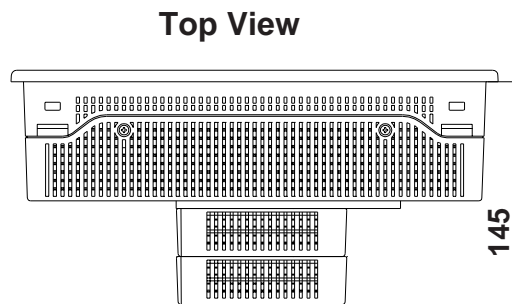

2 Part Names and Functions

The Bus Conversion Unit's part name and its function is explained below.

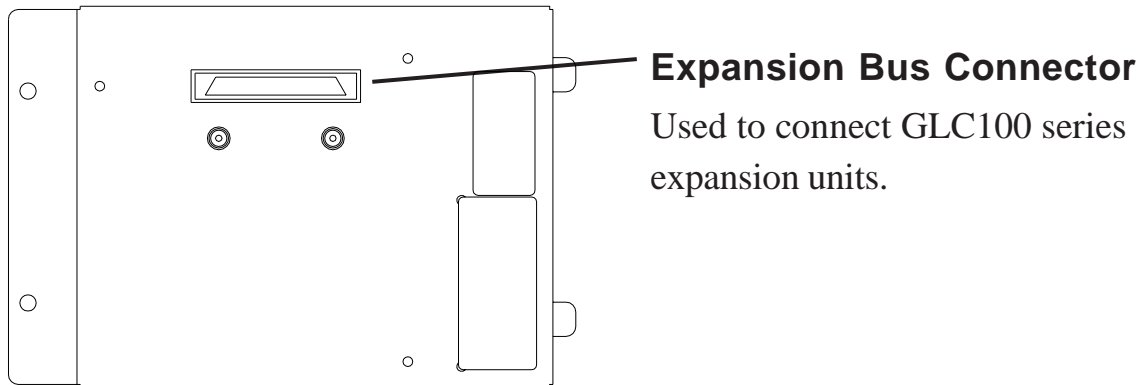

3 General Specifications

■ Environmental Specifications

Operating Temperature	0 to 50 °C
Storage Temperature	-10 to 60 °C
Humidity	20 to 85 %RH (no condensation)
Vibration Resistance	10 to 25 Hz (2 G in X, Y, and Z directions for 30 minutes each)
Operating Atmosphere	Free of corrosive gas

■ Structural Specifications

External Dimensions	167 (W) x 117 (H) x 24.5 (D) mm (Main unit only - excluding projections)
Weight	approx. 350g
Cooling system	Natural air circulation

3 Installation

Use the following procedures to install the Bus Conversion Unit on the GLC.



WARNING

Prior to installing this unit:

- ***When attaching this unit to the GLC, make sure that the GLC's power cord is not plugged in to the main power (constant), to prevent an electric shock.***
- ***Be careful not to touch the surface of this unit's printed circuit board and be sure to wear cotton gloves.***

Attachment Screws

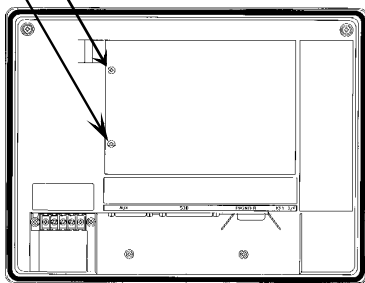

Rear of GLC

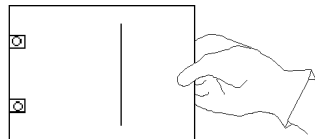

Expansion Unit Cover

1. Turn OFF the GLC.

2. Unscrew the two Expansion unit cover attachment screws on the rear of the GLC, and remove the cover.



CAUTION

- **Do not touch the "copper spring" or the copper spring's contact. Be sure to wear gloves when installing this unit.**

Rear view of Bus Conversion Unit

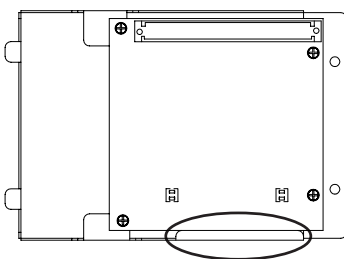

Copper spring contact location

Rear view of GLC

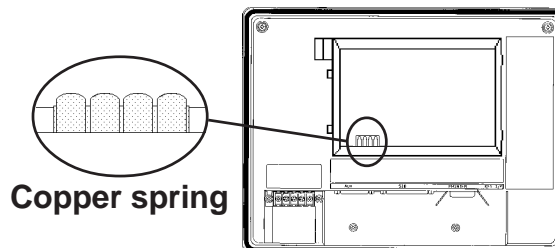

Copper spring

- **Do not remove this unit from the GLC unless absolutely necessary. Excessive attachment and removal can lead to the unit's premature breakdown or malfunction.**

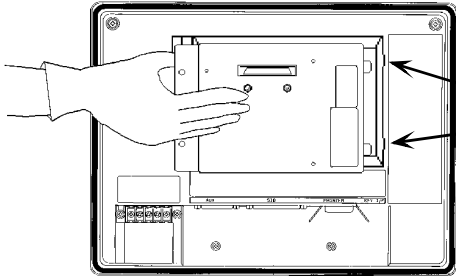

3. Insert the protruding tabs of the Bus Conversion unit into the installation holes.

Be sure to install the unit so that the smooth metal face of the Bus Conversion unit faces outward.

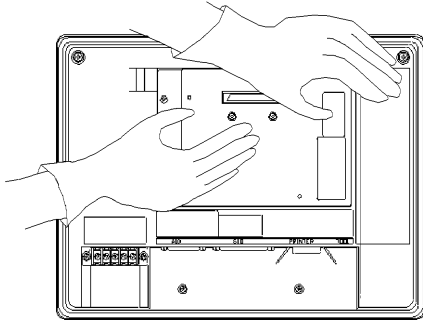

4. Hold the GLC with your left hand and insert the Bus Conversion unit into its slot with your right hand.

Be sure that the unit is seated correctly in place, so that no gaps remain between the GLC and the Bus Conversion unit.

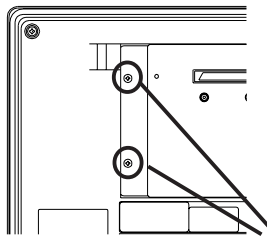

5. Reattach the attachment screws and secure the Bus Conversion unit to the GLC.

**Bus Conversion Unit
Attachment Screws**

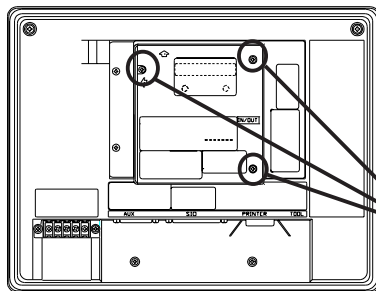

6. Attach the expansion unit to the Bus Conversion unit and tighten the three (3) expansion unit attachment screws (included with unit).

**Attachment
Screws**