

Pro-face

by **Schneider** Electric

Easy! Smooth!

GP3600 Series->GP4600 Series

Replacement Guidebook

Preface

This guidebook introduces the procedures to replace a unit in GP-3600 series with a GP-4600 series.

Model in use	Model No.	Recommended Substitution
GP-3600T	AGP3600-T1-AF AGP3600-T1-D24	GP-4601T
GP-3600T + Video unit *	AGP3600-T1-AF AGP3600-T1-D24	GP-4621T + Video unit *

* VM unit (GP3000-VM01) or RGB unit(GP3000-RGB201)

Safety Information

HAZARD OF OPERATOR INJURY, OR UNINTENDED EQUIPMENT DAMAGE

Before operating any of these products, be sure to read all related manuals thoroughly.

Failure to follow these instructions can result in death, serious injury or unintended equipment damage

GP4000 Series Model Number

GP4000 series model number partly differs depending on a specification. Before placing an order, please make sure of the model number.

PFXGP4 * 0 * * * * *

A

B

C

D

E

F

A	2	GP-4200 series (3.5")
	3	GP-4300 series (5.7")
	4	GP-4400 series (7.5"/7.0"W)
	5	GP-4500 series (10.4")
	6	GP-4600 series (12.1")
B	01	RS-232C/422/485
	03	RS-485 (isolation)
C	T	TFT color LCD
	W	TFT color LCD (Wide Type)
D	A	Analog Resistive Film Touch Panel
	M	Matrix Resistive Film Touch Panel
E	A	AC Type Power Supply
	D	DC Type Power Supply
F	W	GP-4201TW/4301TW/4401WW/4501TW
	C	Coated model
	WC	Coated model of GP-4301TW
	-	None



Contents

<u>PREFACE</u>	<u>2</u>
<u>SAFETY INFORMATION</u>	<u>2</u>
<u>HAZARD OF OPERATOR INJURY, OR UNINTENDED EQUIPMENT DAMAGE</u>	<u>2</u>
<u>GP4000 SERIES MODEL NUMBER</u>	<u>3</u>
<u>CONTENTS</u>	<u>4</u>
<u>CHAPTER 1 SPECIFICATION COMPARISON</u>	<u>6</u>
1.1 SPECIFICATIONS OF GP-3600T AND GP-4601T	6
<u>CHAPTER 2 COMPATIBILITY OF HARDWARE</u>	<u>8</u>
2.1 LOCATIONS OF CONNECTOR	8
2.2 TOUCH PANEL SPECIFICATIONS	9
2.3 TRANSFER CABLE	9
2.4 INTERFACE	10
2.4.1 SERIAL INTERFACE	10
2.4.2 CF CARD INTERFACE	11
2.4.3 USB INTERFACE	11
2.4.4 AUXILIARY I/O INTERFACE (AUX)	11
2.4.5 SOUND OUTPUT INTERFACE	11
2.5 PERIPHERAL UNITS AND OPTION UNITS	12
2.5.1 BARCODE READER CONNECTION	12
2.5.2 PRINTER CONNECTION	12
2.5.3 EXPANSION UNIT	12

2.5.4 ISOLATION UNIT	12
2.6 POWER SUPPLY	14
2.7 BACKUP BATTERY	14
2.8 POWER CONSUMPTION	15
2.9 MATERIALS/COLORS OF THE BODY	15
2.10 ABOUT LADDER MONITOR	15
2.11 OTHER NOTES	15
<u>CHAPTER 3 REPLACEMENT PROCEDURE</u>	<u>16</u>
3.1 WORK FLOW	16
3.2 PREPARATION	17
3.3 RECEIVE SCREEN DATA FROM GP-3600T	17
3.4 CHANGE THE DISPLAY UNIT TYPE	22
3.5 TRANSFER THE SCREEN DATA TO GP-4601T	22
3.6 DIFFERENCES OF SOFTWARE	26
<u>CHAPTER 4 COMMUNICATION WITH DEVICE/PLC</u>	<u>27</u>
4.1 DRIVERS	27
4.1.1 CONNECTABLE DEVICES	27
4.2 SHAPES OF COM PORTS	27
4.3 SIGNALS OF COM PORTS	28
4.3.1 SIGNALS OF COM1	28
4.3.2 SIGNALS OF COM2	30
4.4 MULTILINK CONNECTION	30
4.5 CABLE DIAGRAM AT THE TIME OF REPLACEMENT	31
<u>CHAPTER 5 APPENDIX</u>	<u>34</u>
5.1 CHANGING THE SETTING OF THE EXTERNAL MEDIA TO USE	34

Chapter 1 Specification Comparison

1.1 Specifications of GP-3600T and GP-4601T(Standard model)/GP-4621T(Video unit model)

		GP-3600T	GP-4601T (Standard model)/ GP-4621T (Video unit model)
			
Display Type		TFT Color LCD	
Display Colors		65,536 colors (without blink)/ 16,384 colors (with blink)	
Display Resolution		SVGA (800 × 600 pixels)	
Panel Cutout Dimensions (mm)		W301.5×H227.5mm	
External Dimensions (mm)		W313×H239×D56 mm	W315×H241×D56 mm
Touch Panel Type		Resistive film (Analog)	GP4601T Resistive film (Analog/ Matrix) -> See 2.2 GP-4621T Resistive film (Analog) only
Memory	Application	16MB	UP! 32MB
	SRAM	320KB	
Backup Battery		Secondary Battery (Rechargeable Lithium battery)	NEW! Primary Battery (Replaceable Lithium battery) -> See 2.7
Input Voltage		AC 100 to 240V/ DC 24V	
Serial I/F	COM1	D-Sub 9 pin (plug) RS-232C/422/485	D-Sub 9 pin (plug) RS-232C -> See 2.4.1 and Chapter 4
	COM2	D-Sub 9 pin (socket) RS-422/485	D-Sub 9 pin (plug) RS-422/485 -> See 2.4.1 and Chapter 4
Ethernet I/F		10BASE-T/100BASE-TX	
CF Card I/F		✓	- -> See 2.4.2

SD Card I/F		-	NEW! ✓
USBI/F	Type A	✓ (2 ports)	✓ (1 port) -> See 2.3 and 2.4.3
	Type mini B	-	✓ -> See 2.3
Auxiliary I/O I/F		✓	- -> See 2.4.4
Expansion Unit I/F (For Communication Unit)		✓	- -> See 2.5.3
Expansion Unit I/F (For Video Unit)		✓	GP-4621T Only -> See 2.5.3
Coated model		✓	✓

Chapter 2 Compatibility of Hardware

2.1 Locations of connector

Connector locations of GP-3600T and GP-46x1T;

GP-3600T

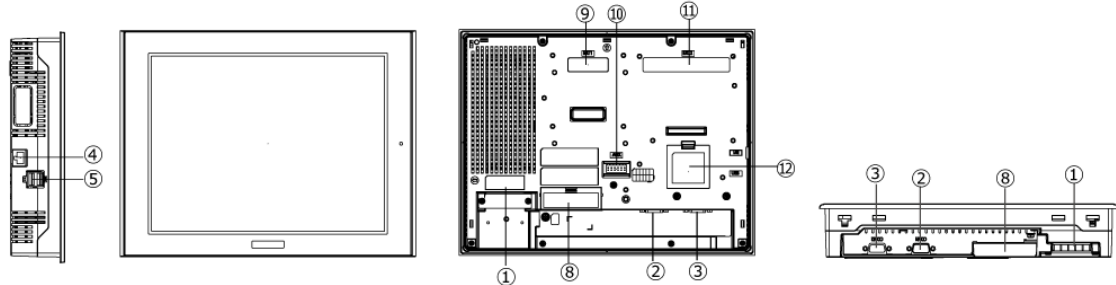

GP-46x1T

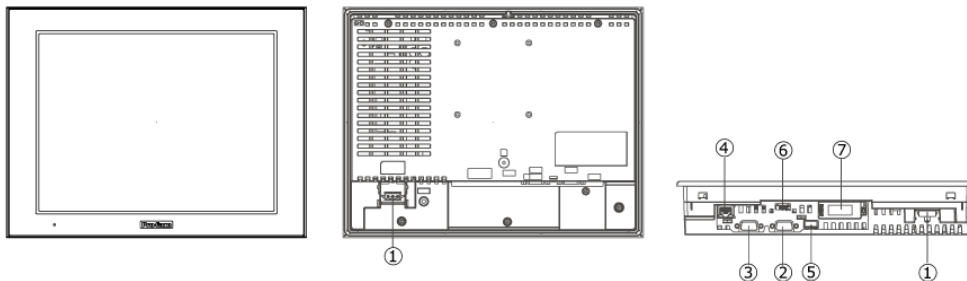

Interface names

	GP-3600T	GP-46x1T
1	Power Input Terminal Block (AC) / Power Connector (DC)	
2	Serial I/F (COM1)	
3	Serial I/F (COM2)	
4	Ethernet I/F	
5	USB I/F (Type A)	
6	-	USB I/F (Type mini B)
7	-	SD Card I/F
8	CF Card I/F	-
9	Expansion Unit I/F (For Communication Unit)	-
10	Auxiliary I/O / Sound Output I/F (AUX)	-
11	Expansion Unit I/F (For VM Unit)	GP-4621T only
12	Function Expansion Memory I/F	-

*For more details of GP-4621T, please refer GP4000 series Hardware manual.

2.2 Touch Panel Specifications

For replacement with GP-4601T, the Matrix resistive film type which enables simultaneous 2-point touch input or the Analog resistive film type with 1-point touch input only can be selected.

When you use 2-point touch input (touching 2 points on the screen at the same time), please select the Matrix resistive film type.



	GP-4601T	
	AC power supply type	DC power supply type
Analog type	PFXGP4601TAA	PFXGP4601TAD
Matrix type	PFXGP4601TMA	PFXGP4601TMD

- GP-4621T(Video unit model) is only analog type.

2.3 Transfer cable

To transfer screen data to GP-46x1T, use a USB transfer cable or Ethernet.

The USB cables that can be used for GP-46x1T are as follows;

	Model	Connector Type	Connector on GP
Options	CA3-USBCB-01		USB (Type A)
	ZC9USCBMB1		USB (Type mini B)
Commercial Item	-		

The same USB transfer cable (CA3-USBCB-01) as that for GP-3600T can be used.

2.4 Interface

2.4.1 Serial Interface

The pin assignment and the shape of plug/socket connector of GP-3600T are the different from those of GP-46x1T.

To know the details about them, see [[4.2 Shapes of COM ports](#)] and [[4.3 Signals of COM ports](#)].

Because of it, the existing PLC connection cables cannot be used as they are for GP-3600T. If you use the existing connection cables, see [[4.5 Cable Diagram at the time of replacement](#)].

When both the COM1 port and the COM2 port have the RS-422/485 setting, only the COM2 port can be used for RS-422/485 connection after replacement.

Using a USB/RS-422/485 Conversion Adapter (PFXZCBCBCVUSR41) may allow you to use GP4000 series' USB interface as RS-422/485 serial interface for connection.

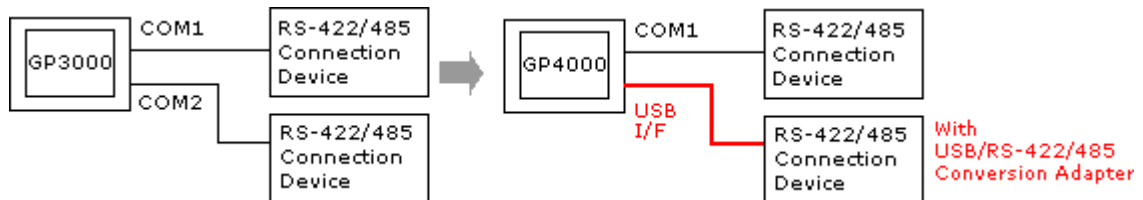

For more information, please refer to USB/RS-422/485 Conversion Adapter Installation Guide.

(<http://www.pro-face.com/otasuke/download/manual/cgi/manual.cgi?mode=33&cat=3>)

IMPORTANT

When using USB/RS-422/485 Conversion Adapter (PFXZCBCBCVUSR41) with a display unit, the device/PLCs you can connect to its serial interface (RS-422/485) are limited. To check the connection configuration, please refer to USB/RS-422/485 Conversion Adapter Connection Guide (http://www.pro-face.com/otasuke/files/manual/gpproex/new/device/data/com_usc.pdf)

2.4.2 CF Card Interface

GP-46x1T is not equipped with a CF card slot. But a SD card slot and a USB interfaces are installed. In order to use the GP-46x1T data saved in the CF card and the functions using the CF card, use a SD card or a USB flash drive instead.

* When using a SD card with GP-46x1T, please verify it supports the following specifications:

	File format	Maximum capacity
SD	FAT16	2GB
SDHC	FAT32	32GB

When the setting of the output destination folder is set to "CF Card" on GP-Pro EX, if you change the display unit type, the setting will automatically change to the one that uses a SD card.

To change the setting of the output destination folder, see [[5.1 Changing the setting of the external media to use](#)].

2.4.3 USB Interface

GP-3600T has two USB ports (USB Type A) but GP-46x1T has only one.

If devices are connected to both USB ports on GP-3600T, use an USB hub for GP-46x1T. Because of bus power limit on GP-46x1T USB port, it's recommended to use an USB hub supporting self-power supply and be sure to check the operation before use.

Also, several USB devices of the same category in the following table cannot be simultaneously used. Even if multiple USB devices of the same category are connected to the display unit, only the first USB device recognized by the display unit can be used.

USB Devices of the same category

Category	USB Device
1	Printer, USB-PIO converter
2	Keyboard, Numeric keys, Barcode reader
3	Mouse
4	USB storage (USB memory, CF/SD card reader, and so on)
5	USB transfer cable
6	USB-Serial (RS-232C) conversion cable, SUB/RS-422/485 Conversion Adapter

2.4.4 Auxiliary I/O Interface (AUX)

GP-46x1T is not equipped with Auxiliary I/O Feature. External Reset Input and 3 Outputs (RUN Output, System Alarm Output, and External Buzzer Output) that can be used for GP-3600T cannot be used.

2.4.5 Sound Output Interface

GP-46x1T is not equipped with the sound output function. The sound output function for GP-3600T cannot be used.

2.5 Peripheral units and option units

2.5.1 Barcode reader connection

Like GP3000 series, GP-46x1T allows you to connect a barcode reader to its USB interface (Type A) or its serial interface.

For the models GP4000 series supports, see [OtasukePro!]

(http://www.pro-face.com/otasuke/qa/3000/0056_connect_e.html).

2.5.2 Printer connection

Like GP3000 series, GP-46x1T allows you to connect a printer on its USB interface (Type A).

For the models GP4000 series supports, see [OtasukePro!]

(http://www.pro-face.com/otasuke/qa/3000/0056_connect_e.html).

2.5.3 Expansion Unit

- GP-46x1T is not equipped with an expansion unit interface. The expansion unit (each kind of unit like CC-LINK Unit) for GP3000 SERIES cannot be used.
- GP-4621T supports the following video units.

Video units for GP-3600T	Video units for GP-4621T
GP3000 series VM unit (GP3000-VM01)	Supported
RGB unit (GP3000-RGB201)	
DVI Input unit (GP3000-DVI01)	Not supported. Please replace to GP3000 series VM unit(GP3000-VM01) and use a DVI-I input port on VM unit.
GP2000 series VM unit (GP2000-VM41)	Not supported. Please replace to GP3000 series VM unit(GP3000-VM01)

2.5.4 Isolation Unit

RS-485 isolation unit for GP-3600T (CA3-ISO485-01) cannot be used for GP-46x1T. You can use the RS-232C isolation unit (CA3-ISO232-01) for GP-46x1T instead.

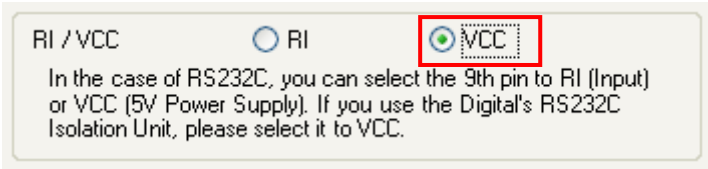
Note for using RS-232C isolation unit (CA3-ISO232-01)
<ul style="list-style-type: none"> • Connect it to GP4000 series via COM1 (232C). COM2 cannot be used. • It's necessary to set the 9th pin of the COM port to VCC. [Settings on GP-ProEX] Select "VCC" from [System Settings] -> [Device/PLC] in the [Project] menu on GP-Pro EX.
 <p>RI / VCC <input type="radio"/> RI <input checked="" type="radio"/> VCC</p> <p>In the case of RS232C, you can select the 9th pin to RI (Input) or VCC (5V Power Supply). If you use the Digital's RS232C Isolation Unit, please select it to VCC.</p>

- RS-422/485 (2-wire type) communication and serial multilink are not supported.

2.6 Power Supply

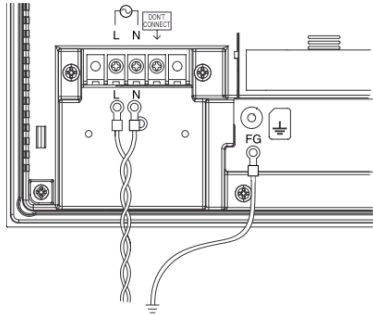
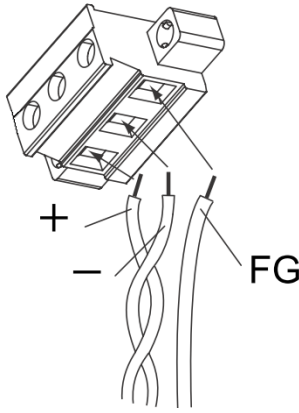
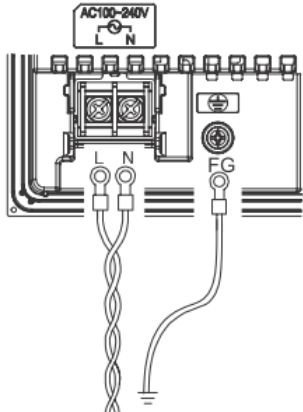
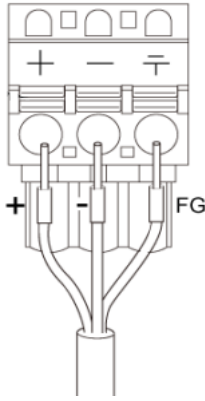
	AC Type	DC Type	
GP3000 Series			CA5-DCCNL-01 made by Pro-face Or GMVSTBW2,5/3-S TF-7,62 made by PHOENIX CONTACT
GP4000 Series			PFXZCBCNDC2 made by Pro-face
Compat ibility	Compatible because of a terminal block. FG has been relocated.	Not compatible because of different pitch though the connectors have the same shape. Use the specified type of connector.	

2.7 Backup Battery

Unlike GP3000 series, GP4000 series does not use rechargeable secondary batteries but replaceable primary ones. (For both a rechargeable type and a replaceable one, contents to be backed up are the same.)

When the time for replacement of backup batteries approaches, the message to urge you to replace the battery, "RAAA053: Running out of power in the backup battery. Please change the battery." appears. When the message appears, replace the battery referring to the GP4000 series hardware manual.

Replaceable Battery Model
PFXZCBBT1

2.8 Power Consumption

The power consumption of GP-3600T is different from that of GP-46x1T.

	AC Type	DC Type
GP-3600T	90VA or less (AC100V) 108VA or less (AC240V)	50W or less
GP-4601T	44VA or less (AC100V) 58VA or less (AC240V)	17W or less
GP-4621T	56VA or less (AC100V) 77VA or less (AC240V)	

For the detailed electric specifications, see the hardware manual.

2.9 Materials/Colors of the body

The materials and the colors of GP-3600T and GP-46x1T are as follows:

	GP-3600T	GP-46x1T
Color	Silver	Gray
Material	Aluminum alloy Light	Resin with glass

2.10 About Ladder monitor

PLC Ladder monitor tool cannot be used for GP4000 series.

2.11 Other Notes

- Do not expose GP4000 series to direct sunlight.
- Do not use GP4000 series outdoors.
- Do not turn on GP4000 series if condensation has occurred inside the device.
- When you are continuously using GP4000 series without oxygen, the brightness might decrease. Please ventilate the control panel periodically.

Chapter 3 Replacement Procedure

3.1 Work Flow

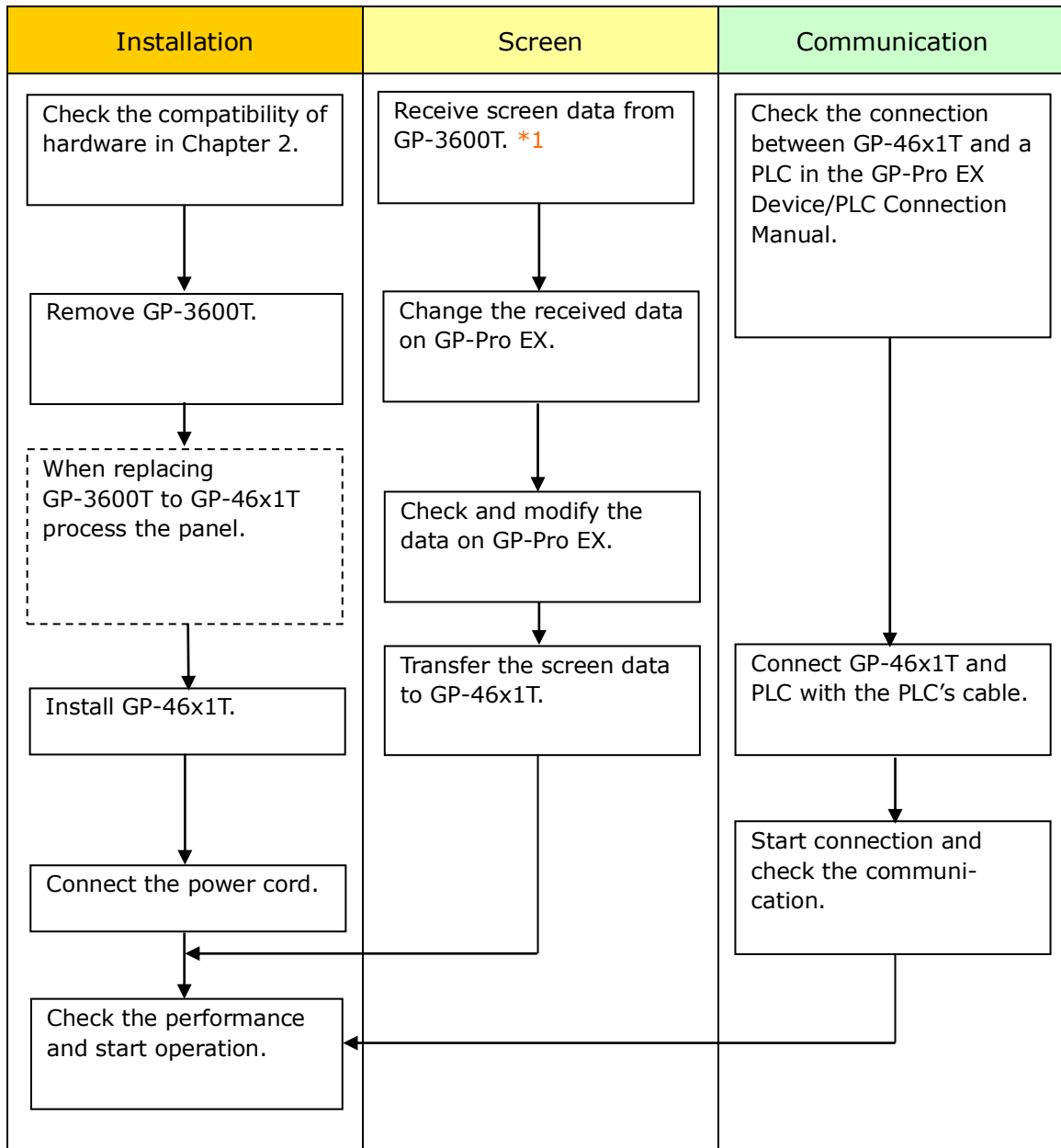

*1: This step is required if screen data is saved only in the GP unit, not in any other device.

3.2 Preparation

Requirements for receiving screen data from GP-3600T *1	PC in which GP-Pro EX Transfer Tool is installed. *2 USB Transfer Cable (model: CA3-USBCB-01) * Possible to send/receive a screen via a CF card, a USB storage device or Ethernet.
Requirements for converting screen data of GP-3600T and transferring the converted data to GP-46x1T.	PC in which GP-Pro EX Ver.3.01 or later is installed. (GP-4621T is supported GP-Pro EX Ver.4.07.300 or later) Transfer Cable (The following three types of cables are available) <ul style="list-style-type: none"> • A USB transfer cable (model: CA3-USBCB-01) • A USB data-transfer cable (model: ZC9USCBMB1) • A commercial USB cable (USB Type A/mini B) * Possible to send/receive a screen via a SD card , a USB storage device or Ethernet.

*1: This step is required if screen data is saved only in the GP unit, not in any other device.

*2: Please use the same version or later as or than that of the software used during creating screens on GP-3600T. If you don't know the version, we recommend you to use the newest version. For the newest version, you can download the transfer tool from our web site called [OtasukePro!]
(http://www.pro-face.com/otasuke/download/freesoft/gpprox_transfer.htm).

3.3 Receive screen data from GP-3600T

You can transfer data to GP-3600T via;

- A USB transfer cable (model: CA3-USBCB-01)
- A CF card/USB storage device
- Ethernet

But this section explains, as an example, how to receive screen data from GP-3600T using a USB transfer cable (model: CA3-USBCB-01).

If you have backed up screen data, this step is unnecessary, skip to the next section [[3.4 Change the Display Unit Type](#)].



PC



USB transfer cable
(CA3-USBCB-01)



GP

- (1) Connect your PC and GP-3600T with a USB transfer cable.
If the driver of the cable has not been installed on your PC yet, a dialog box will appear. Please follow the instructions.

NOTE

- The "Hardware Installation" dialog box as shown below may appear during installing the USB driver depending on the security level of Windows® XP. Click [Continue Anyway] to start installing the driver. When installation is completed, click [Finish].

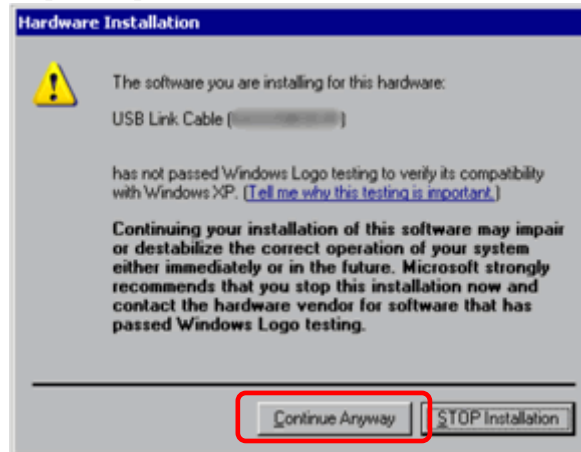

- If the following symptoms appear on Microsoft Windows® 7, go to updating "USB Data Transfer Driver" on [OtasukePro!] for download. (http://www.pro-face.com/otasuke/download/freesoft/gpprox_transfer.htm)
 - An error occurs when GP-Pro EX or Transfer Tool is installed
 - An error occurs when data is transferred via a USB transfer cable (model: CA3-USBCB-01).

(2) Start the Transfer Tool of GP-Pro EX.

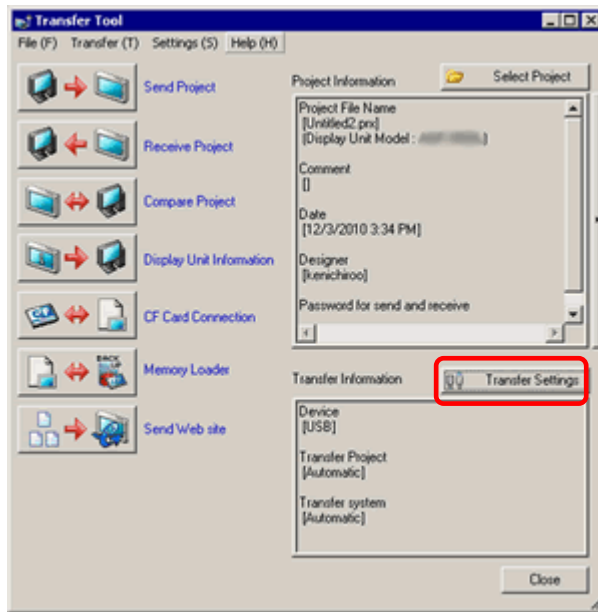

(3) Make sure that the [Device] in the "Transfer Settings Information" is set to [USB]. If not, click the [Transfer Setting] button to open the "Transfer Setting" dialog box. Select [USB] in the Communication Port Settings field and click [OK].



(4) Start GP-Pro EX Transfer Tool and click the [Receive Project] button.

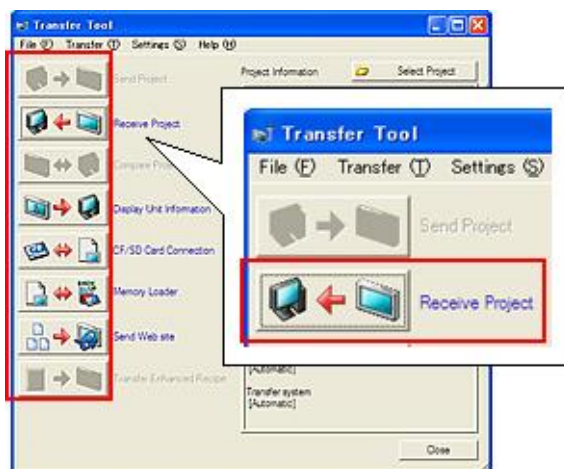

- (5) Click [Receive Project], and the following dialog box will appear. Specify a place to save the received data in and a project file name, and then click [Save] to start transfer.

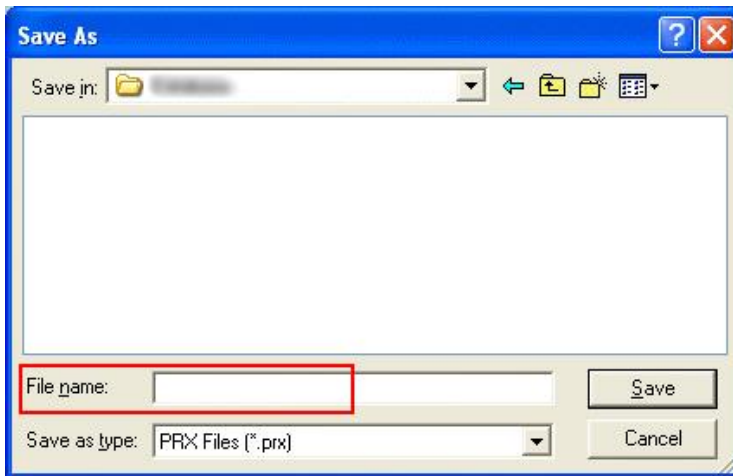

NOTE

When a file exists, the window that confirms whether or not to overwrite the file is displayed.

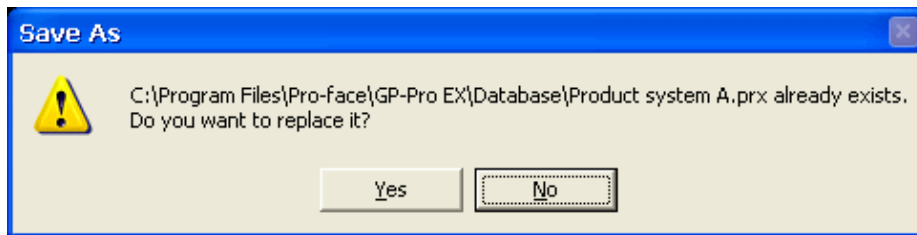

- (6) The following dialog box appears during transfer and you can check the communication status. (The display unit enters the Transferring mode and communication with the device such as a PLC is terminated.)

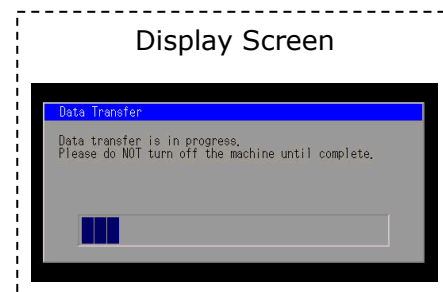
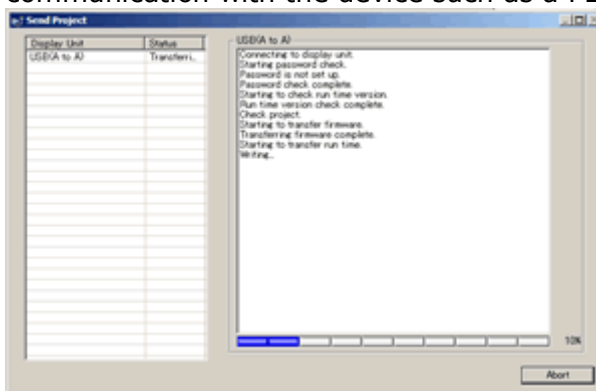

NOTE

- If you receive the project files that use CF card data such as Recipe Function (CSV data), the following dialog box will appear during transfer. Specify a place to save the CF card data in. Click [OK], and the [Receive Project] dialog box will return and transfer will be completed.



- GP-46x1T that is a replacement model is not equipped with a CF card slot. If the display unit type is changed to GP4000 series, the CF card setting will be replaced with the SD card setting automatically. To check or change the destination folder setting, see [[5.1 Changing the setting of the external media to use](#)].

- (7) When transfer is completed, the status displayed in the dialog box will change from [Transferring] to [Complete Transfer]. Click [Close] to close the dialog box.

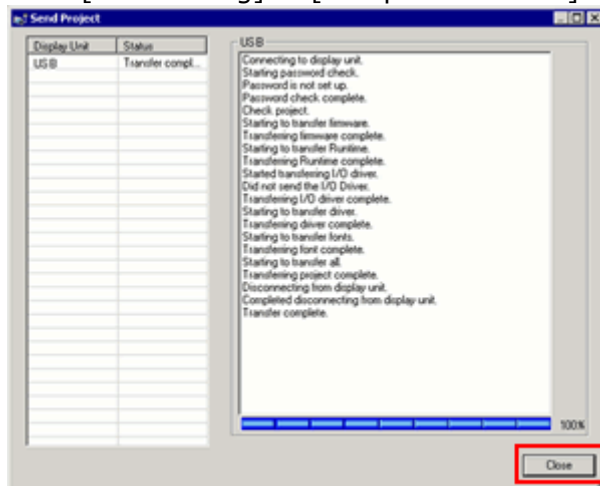

- (8) Close the Transfer Tool.

3.4 Change the Display Unit Type

Open the received project file (*.prx) of GP3000 series on GP-Pro EX and change the display unit type to GP4000 series.

- (1) Open the received project file (*.prx) on GP-Pro EX.
- (2) Click [System Settings]->[Display]->[Change Display] in [Project] menu and change the Display Unit type to the replacement model.
- (3) Click [Project]->[Save As] and save the changed project file.

3.5 Transfer the screen data to GP-46x1T

Transfer the project file after the display unit type change to GP-46x1T.

You can transfer data to GP-46x1T via;

- An USB transfer cable (model: CA3-USBCB-01)
- An USB data transfer cable (model: ZC9USCBMB1)
- A commercial USB cable (USB Type A/mini B)
- A SD card/USB storage device
- Ethernet

But, this section explains, as an example, how to transfer screen data with an USB transfer cable (model: CA3-USBCB-01).



- (1) Connect your PC and the GP unit of GP-46x1T with a USB transfer cable. If the driver of the cable has not been installed on you PC, a dialog box will appear. Please follow the instructions.

NOTE

- The "Hardware Installation" dialog box as shown below may appear during installing the USB driver depending on the security level of Windows® XP. Click [Continue Anyway] to start installing the driver. When installation is completed, click [Finish].



- If the following symptoms appear on Microsoft Windows® 7, go to updating "USB Data Transfer Driver" on [OtasukePro!] for download (http://www.pro-face.com/otasuke/download/freesoft/gporex_transfer.htm).
 - An error occurs when GP-Pro EX or Transfer Tool is installed
 - An error occurs when data is transferred via a USB transfer cable (model: CA3-USBCB-01).

- (2) Turn on the power of GP-46x1T. The "Initial Start Mode" screen will appear on the display unit. After transferring a project file once, this screen will not appear again.



- (3) On the GP-Pro EX's State Toolbar, click the [Transfer Project] icon to open the Transfer Tool.

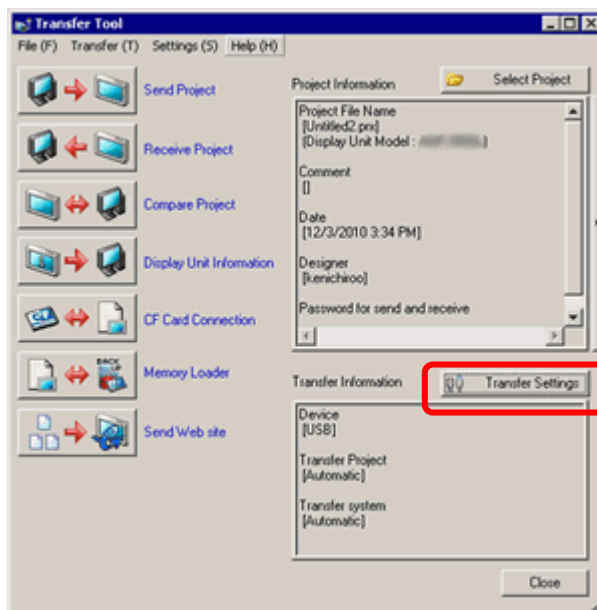

To transfer a different project file, click the [Select Project] button and select a project file.

- (4) Make sure that the [Device] in the "Transfer Settings Information" is set to [USB]. If not, click the [Transfer Setting] button to open the "Transfer Setting" dialog box. Select [USB] in the Communication Port Settings field and click [OK].



- (5) Click [Send Project] to start transfer. When the following dialog box appears, click [Yes]. This dialog box doesn't appear when the same project file is sent again.

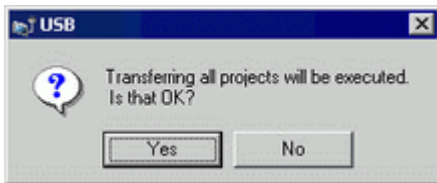

- (6) The following dialog box appears during transfer and you can check the communication status. (The display unit enters the Transferring mode and communication with the device such as a PLC is terminated.)

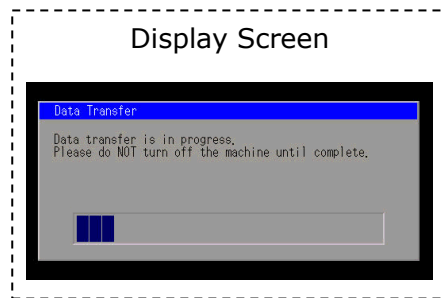
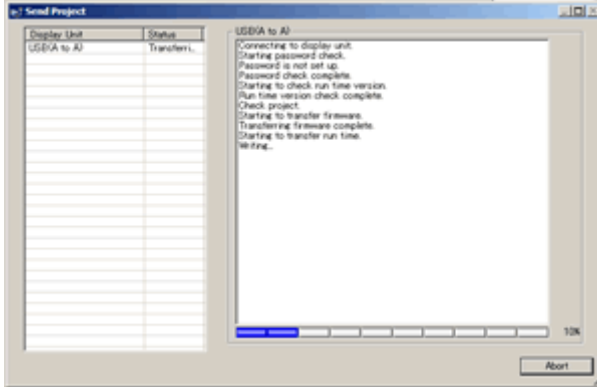

- (7) When transfer is completed, the status displayed in the dialog box will change from [Transferring] to [Complete Transfer]. Click [Close] to close the dialog box.

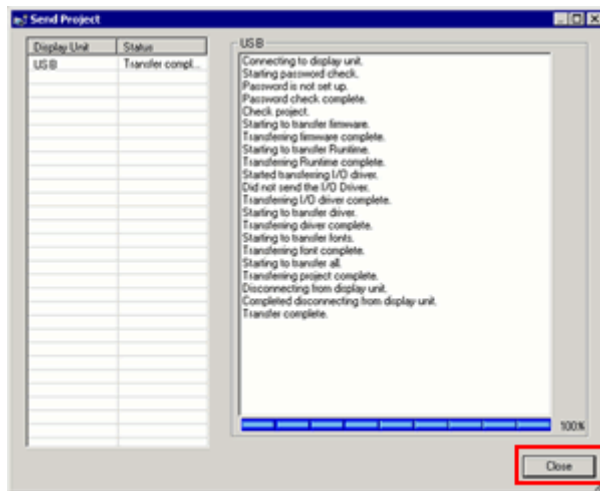

The display unit will be reset and a screen of the transferred project file will be displayed.

- (8) Close the Transfer Tool.
- (9) Click the [X] mark on top right of the screen or [Project]->[Exit] to close GP-Pro EX.

3.6 Differences of software

Some functions supported by GP-3600T are not supported by GP-46x1T. For details of the supported parts and functions, refer to [Supported Features] of GP-Pro EX Reference Manual

(<http://www.pro-face.com/otasuke/files/manual/gpproex/new/refer/gpproex.htm>).

Chapter 4 Communication with Device/PLC

4.1 Drivers

4.1.1 Connectable Devices

More connectable drivers will be added.

For the devices/PLC each driver supports, see [Connectable Devices] (<http://www.pro-face.com/product/soft/qproex/driver/driver.html>).

4.2 Shapes of COM ports

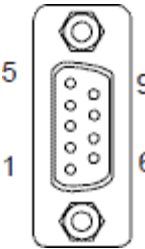
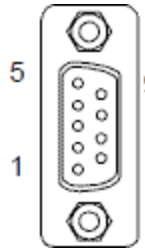
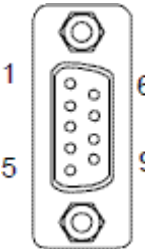
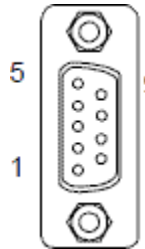
	GP-3600T	GP-46x1T
COM1	D-Sub 9 pin (plug) RS-232C/422/485	D-Sub 9 pin (plug) RS-232C
		
COM2	D-Sub 9 pin (socket) RS-422/485	D-Sub 9 pin (plug) RS-422/485
		

MEMO

To use the connection cable used for GP-3600T, see [4.5 Cable Diagram at the time of replacement](#).

4.3 Signals of COM ports

4.3.1 Signals of COM1

For GP-3600T

RS-232C (plug)

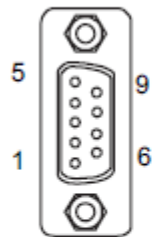
Pin Connection	Pin No.	RS-232C		
		Signal Name	Direction	Meaning
 <p>(GP unit side)</p>	1	CD	Input	Carrier Detect
	2	RD(RXD)	Input	Receive Data
	3	SD(TXD)	Output	Send Data
	4	ER(DTR)	Output	Data Terminal Ready
	5	SG	-	Signal Ground
	6	DR(DSR)	Input	Data Set Ready
	7	RS(RTS)	Output	Request to Send
	8	CS(CTS)	Input	Send possible
	9	CI(RI)/VCC	Input/-	Called Status Display +5V±5% Output 0.25A
	Shell	FG	-	Frame Ground (Common with SG)

RS-422/485 (plug)

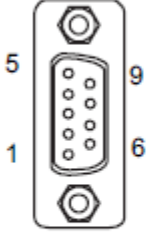
Pin Connection	Pin No.	RS-422/RS-485		
		Signal Name	Direction	Meaning
 <p>(GP unit side)</p>	1	RDA	Input	Receive Data A (+)
	2	RDB	Input	Receive Data B (-)
	3	SDA	Output	Send Data A (+)
	4	ERA	Output	Data Terminal Ready A (+)
	5	SG	-	Signal Ground
	6	CSB	Input	Send Possible B (-)
	7	SDB	Output	Send Data B (-)
	8	CSA	Input	Send Possible A (+)
	9	ERB	Output	Data Terminal Ready B (-)
	Shell	FG	-	Frame Ground (Common with SG)

For GP-46x1T
RS-232C (plug)

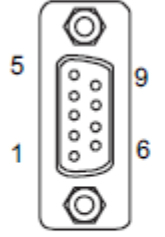
Pin Connection	Pin No.	RS-232C		
		Signal Name	Direction	Meaning
 <p>(GP unit side)</p>	1	CD	Input	Carrier Detect
	2	RD(RXD)	Input	Receive Data
	3	SD(TXD)	Output	Send Data
	4	ER(DTR)	Output	Data Terminal Ready
	5	SG	-	Signal Ground
	6	DR(DSR)	Input	Data Set Ready
	7	RS(RTS)	Output	Request to Send
	8	CS(CTS)	Input	Send possible
	9	CI(RI)/VCC	Input/-	Called Status Display +5V±5% Output 0.25A ^{*1}
	Shell	FG	-	Frame Ground (Common with SG)

*1: RI and VCC of Pin 9 are switched on the software.

VCC Output is not protected from overcurrent.

Please follow the current rating to avoid false operation or breakdown.

4.3.2 Signals of COM2

For GP-3600T

RS-422/485 (socket)

Pin Arrangement	Pin No.	RS422/RS485		
		Signal Name	Direction	Meaning
 (GP unit side)	1	TRMRX	-	Termination (Receiver side: 100Ω)
	2	RDA	Input	Receive Data A(+)
	3	SDA	Output	Send Data A(+)
	4	RS(RTS)	Output	Request for Send
	5	SG	-	Signal Ground
	6	VCC	-	+5V±5% Output 0.25A *1
	7	RDB	Input	Receive Data B(-)
	8	SDB	Output	Send Data B(-)
	9	TRMTX	-	Termination (Receiver side: 100Ω)
	Shell	FG	-	Frame Ground (Common with SG)

For GP-46x1T

RS-422/485 (plug)

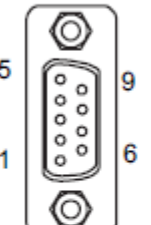
Pin Connection	Pin No.	RS-422/RS-485		
		Signal Name	Direction	Meaning
 (GP unit side)	1	RDA	Input	Receive Data A (+)
	2	RDB	Input	Receive Data B (-)
	3	SDA	Output	Send Data A (+)
	4	ERA	Output	Data Terminal Ready A (+)
	5	SG	-	Signal Ground
	6	CSB	Input	Send Possible B (-)
	7	SDB	Output	Send Data B (-)
	8	CSA	Input	Send Possible A (+)
	9	ERB	Output	Data Terminal Ready B (-)
	Shell	FG	-	Frame Ground (Common with SG)

4.4 Multilink Connection

For the communication drivers that support serial multi-link, see [Which drivers support serial multilink communication?]

(http://www.pro-face.com/otasuke/files/manual/gpproex/new/device/com_mlnk.htm).

4.5 Cable Diagram at the time of replacement

The connection cable for GP-3600T can be used for GP-46x1T.

But please note that there are precautions and restrictions as described below **when replacing GP-3600T.**

- When a RS-422/485 device is connected via the COM1 port, **if GP-3600T is replaced with GP4000 series, it will be connected via the COM2 port of GP4000 series.** (The cable diagram can be still used.)

Before GP-46x1T is connected, be sure to change the port setting to COM2 on the Device/PLC setting. Also, please check the communication settings with GP-Pro EX Device/PLC Connection Manual just in case.

(<http://www.pro-face.com/otasuke/files/manual/gpproex/new/device/index.htm>

)

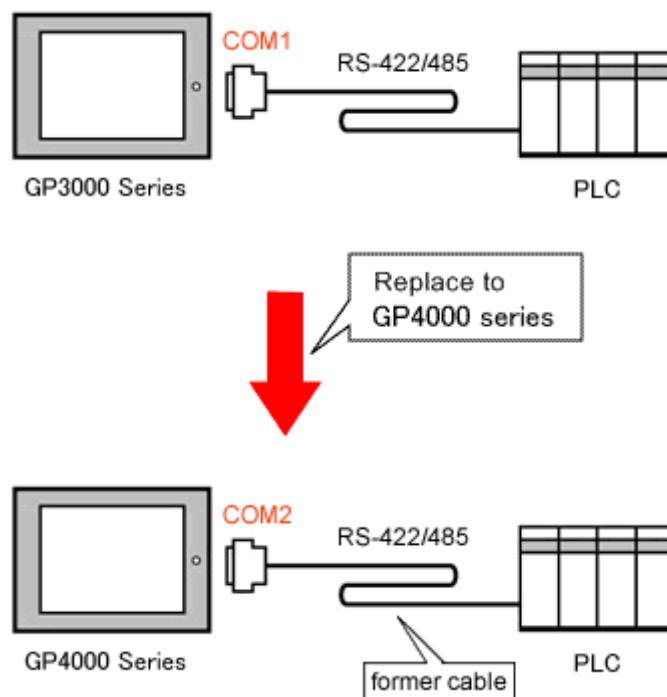

- The cable used for connection to **GP-3600T via COM2** can be used for GP4000 series with a COM Port Conversion Adapter (CA3-ADPCOM-01) added in the following cases;

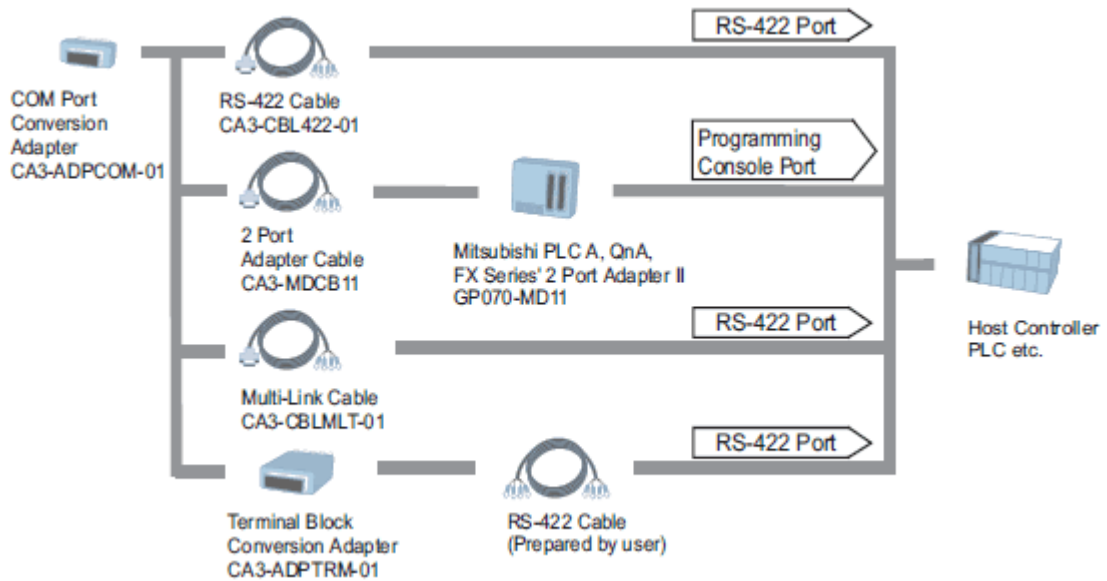

In all other cases, the operation is not guaranteed and it's recommended to prepare a new connection cable. To check the cable diagram, please refer to GP-Pro EX Device/PLC Connection Manual.

Important

If the homemade COM 2 cable diagram for GP-3600T is used for GP-4601 with a COM port conversion adapter (CA3-ADPCOM-01), no operation is guaranteed. It's recommended to get a new cable diagram prepared for GP-46x1T. For cable diagrams, see GP-Pro EX Device/PLC Connection Manual.
(<http://www.pro-face.com/otasuke/files/manual/gpproex/new/device/index.htm>)

- When both the COM1 port and the COM2 port have the RS-422/485 setting, only the COM2 port can be used for RS-422/485 connection after replacement with GP4000 series.
Using a USB/RS-422/485 Conversion Adapter may allow you to use GP4000 series' USB interface as RS-422/485 serial interface for connection.
For more information, please refer to USB/RS-422/485 Conversion Adapter Installation Guide.
(<http://www.pro-face.com/otasuke/download/manual/cgi/manual.cgi?mode=33&cat=3>)

Important

The connected devices/PLC which can connect to the serial interface side of USB/RS-422/485 Conversion Adapter are limited. For details, see USB/RS-422/485 Conversion Adapter Connection Guide
(http://www.pro-face.com/otasuke/files/manual/gpproex/new/device/data/com_usc.pdf)

Chapter 5 Appendix

5.1 Changing the setting of the external media to use

If a CF card is used for GP3000 series, after the display unit type of the project file is changed to GP4000 series, "a CF card" is automatically replaced with "a SD card" for the external media setting.

- (1) After conversion of the project file data, at GP-Pro EX Error Check, if the message, "The project contains features that require a SD card. However, the selected display does not support SD cards so these features will not run." appears,

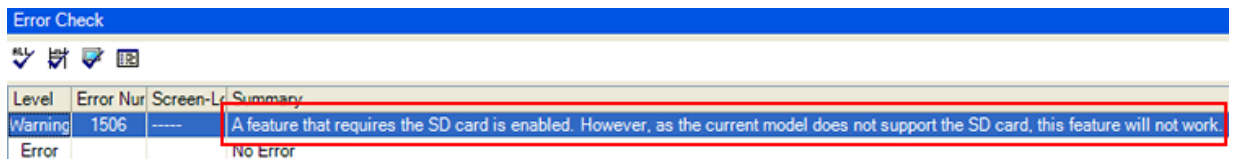

Level	Error Num	Screen-Id	Summary
Warning	1506	----	A feature that requires the SD card is enabled. However, as the current model does not support the SD card, this feature will not work.
Error			No Error

<Cause>

The model without a SD card slot has the setting that uses a SD card.

->[Solution 1](#)

- (2) To use a USB flash drive instead of a SD card ->[Solution 1](#)

- (3) To check or change the SD card's data output destination folder setting

->[Solution 2](#)

[Solution]

1. Change the SD Card setting to the USB storage setting following the steps below.

<Procedure>

- i. Click [Project]->[Information]->[Destination Folder].
- ii. Uncheck "Enable SD Card" and check "Enable USB Storage".

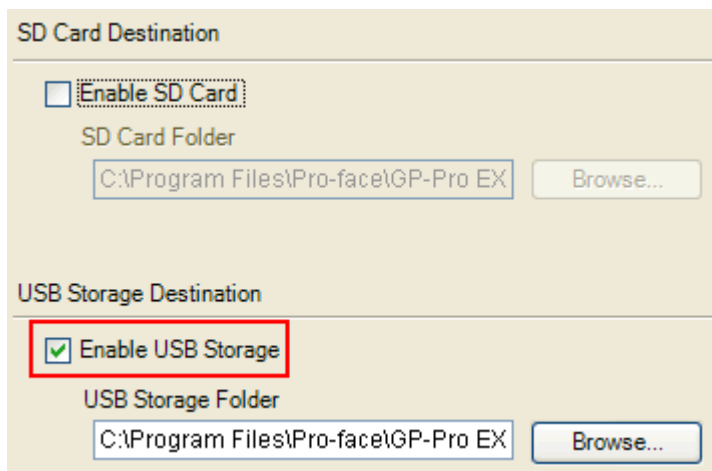

iii. Click the [Browse] button and specify a destination folder.

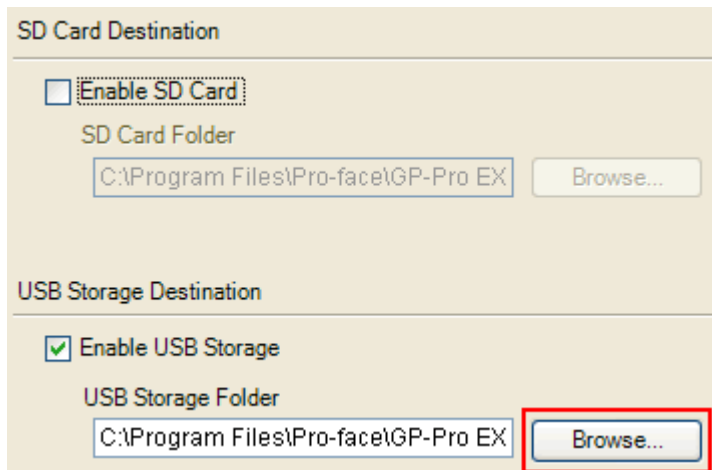

- iv. Click [OK] to confirm the setting.
- v. Click [Project]->[Save] to save changes.
- vi. Check each function that uses the CF card and replace the setting of [SD Card] with the one of [USB Storage].

NOTE

To check each function setting of GP-Pro EX, refer to GP-Pro EX Reference Manual.

2. Check and change the destination folder setting following the steps below.
 - i. Click [Project]->[Information]->[Destination Folder].
 - ii. The current setting is displayed.

The screenshot shows two sections of a settings dialog box. The top section is titled "SD Card Destination" and contains an unchecked checkbox labeled "Enable SD Card". Below it is the label "SD Card Folder" followed by a text input field containing the path "C:\Program Files\Pro-face\GP-Pro EX" and a "Browse..." button. The bottom section is titled "USB Storage Destination" and contains a checked checkbox labeled "Enable USB Storage". Below it is the label "USB Storage Folder" followed by a text input field containing the path "C:\Program Files\Pro-face\GP-Pro EX" and a "Browse..." button.

- iii. After changing it, click [OK] to confirm the setting.
 - iv. Click [Project]->[Save] to save changes.