

GP6000 Series

Advanced Model

Hardware Guide

GP6000-MM01-EN.01

05/2026

Legal Information

The information provided in this document contains general descriptions, technical characteristics and/or recommendations related to products/solutions.

This document is not intended as a substitute for a detailed study or operational and site-specific development or schematic plan. It is not to be used for determining suitability or reliability of the products/solutions for specific user applications. It is the duty of any such user to perform or have any professional expert of its choice (integrator, specifier or the like) perform the appropriate and comprehensive risk analysis, evaluation and testing of the products/solutions with respect to the relevant specific application or use thereof.

The Pro-face brand and any trademarks of Schneider Electric and its subsidiaries referred to in this document are the property of Schneider Electric or its subsidiaries. All other brands may be trademarks of their respective owner.

This document and its content are protected under applicable copyright laws and provided for informative use only. No part of this document may be reproduced or transmitted in any form or by any means (electronic, mechanical, photocopying, recording, or otherwise), for any purpose, without the prior written permission of Schneider Electric.

Schneider Electric does not grant any right or license for commercial use of the document or its content, except for a non-exclusive and personal license to consult it on an "as is" basis.

Electrical equipment should be installed, operated, serviced, and maintained only by qualified personnel. No responsibility is assumed by Schneider Electric for any consequences arising out of the use of this material.

Schneider Electric reserves the right to make changes or updates with respect to or in the content of this document or the format thereof, at any time without notice.

To the extent permitted by applicable law, no responsibility or liability is assumed by Schneider Electric and its subsidiaries for any errors or omissions in the informational content of this document, as well as any non-intended use or misuse of the content thereof.

Table of Contents

Table of Contents	3
Safety Information	5
About the Document	6
Cybersecurity	13
Cybersecurity Guideline	13
Security Seal	13
Overview	14
Model Numbers	14
Package Contents	15
Package Contents (Panel Mount Type)	15
Package Contents (DIN Mount Type)	16
Product Revision and QR Code	16
Certifications and Standards	17
Federal Communication Commission Radio Frequency Interference Statement - For USA	18
Hazardous Location Installation - For USA and Canada	19
Device Connectivity	21
System Design	21
System Design (Panel Mount Type)	21
System Design (DIN Mount Type)	22
Accessories	23
Maintenance Accessories	25
Parts Identification and Functions	27
Parts Identification (Panel Mount Type)	27
Parts Identification (10, 12, 15-inch Model)	27
Parts Identification (10, 12, 15, 19, 22-inch Wide Model)	29
LED Indications (Panel Mount Type)	31
Status LED (Front LED)	31
Ethernet LED	31
Rear LEDs	31
Parts Identification (DIN Mount Type)	32
LED Indications (DIN Mount Type)	34
Specifications	36
General Specifications (Panel Mount Type)	36
Electrical Specifications (Panel Mount Type)	36
Environmental Specifications (Panel Mount Type)	39
Structural Specifications (Panel Mount Type)	40
General Specifications (DIN Mount Type)	42
Electrical Specifications (DIN Mount Type)	42
Environmental Specifications (DIN Mount Type)	43
Structural Specifications (DIN Mount Type)	44
Functional Specifications	45
Display Specifications	45
Touch Panel	46
Memory	46
Clock	46
Interface Specifications	46
Specifications of Each Interface	46

Interface Connection	48
Serial Interface.....	51
Eject Button	53
Dimensions	54
External Dimensions (10-inch Model)	54
External Dimensions (12-inch Model)	55
External Dimensions (15-inch Model)	55
External Dimensions (10-inch Wide Model).....	56
External Dimensions (12-inch Wide Model).....	57
External Dimensions (15-inch Wide Model).....	57
External Dimensions (19-inch Wide Model).....	58
External Dimensions (22-inch Wide Model).....	59
Installation Fastener.....	59
External Dimensions (DIN Mount Type)	60
Dimensions with DIN Rail Attachment Installed.....	61
Installation and Wiring.....	62
Installation of Panel Mount Type.....	62
Precautions for Building into an End-use Product.....	62
Installation Requirements	63
Panel Cutout Dimensions	64
Installation Procedure.....	65
Removal Procedure.....	67
Installation of DIN Mount Type	69
Precautions for Installing onto an End-use Product	69
Installation Requirements (DIN Mount Type)	69
Installing onto DIN Rail	71
Removal from DIN Rail	73
Wiring the Power Supply	74
AC/DC Power Cord Preparation	74
How to Connect the AC Power Cord	75
How to Connect the DC Power Cord	76
Power Supply Precautions	77
Grounding	79
USB Cable Clamp.....	81
Front USB Cover	83
SD Card Installation	85
Expansion Unit	87
VESA Mounting	87
Attaching the VESA Mounting Plate	88
Isolation Unit Installation Procedure	90
Maintenance	93
Regular Cleaning	93
Periodic Check Points	93
Replacing the Installation Gasket	94
Replacing the Display Module or Box Module.....	94
Removing the Display Module	95
Installing the Display Module.....	96
Replacing the Battery	97
After-sales Service.....	98

Safety Information

Important Information

Read these instructions carefully, and look at the equipment to become familiar with the device before trying to install, operate, service, or maintain it. The following special messages may appear throughout this documentation or on the equipment to warn of potential hazards or to call attention to information that clarifies or simplifies a procedure.



The addition of this symbol to a "Danger" or "Warning" safety label indicates that an electrical hazard exists which will result in personal injury if the instructions are not followed.



This is the safety alert symbol. It is used to alert you to potential personal injury hazards. Obey all safety messages that follow this symbol to avoid possible injury or death.

DANGER

DANGER indicates a hazardous situation which, if not avoided, **will result in** death or serious injury.

WARNING

WARNING indicates a hazardous situation which, if not avoided, **could result in** death or serious injury.

CAUTION

CAUTION indicates a hazardous situation which, if not avoided, **could result in** minor or moderate injury.

NOTICE

NOTICE is used to address practices not related to physical injury.

Please Note

Electrical equipment should be installed, operated, serviced, and maintained only by qualified personnel. No responsibility is assumed by Schneider Electric for any consequences arising out of the use of this material.

A qualified person is one who has skills and knowledge related to the construction and operation of electrical equipment and its installation, and has received safety training to recognize and avoid the hazards involved.

About the Document

Document Scope

This document describes the specifications, installation, operation, and maintenance of the GP6000 Series Advanced Model, which is an HMI (Human Machine Interface) device used in industrial or factory automation systems.

This document is intended for users who design systems, or install and maintain components.

Validity Note

This document is valid for the GP6000 Series Advanced Model.

The characteristics of the products described in this document are intended to match the characteristics that are available on www.pro-face.com. As part of our corporate strategy for constant improvement, we may revise the content over time to enhance clarity and accuracy. If you see a difference between the characteristics in this document and the characteristics on www.pro-face.com, consider www.pro-face.com to contain the latest information.

Product Related Information

This product has been designed, developed and manufactured for use in industrial or factory automation systems.

- The product is not appropriate for use with aircraft control devices, medical life-support equipment, central trunk data transmission (communication) devices, or nuclear power control devices, due to inherent requirements for extremely high levels of safety and reliability.
- When using the product with transportation vehicles (trains, cars, and ships), disaster and crime prevention devices, safety equipment, or medical devices unrelated to life-support systems, use redundant and/or failsafe system designs to ensure reliability and safety.

If the equipment is used in a manner not specified by the manufacturer, the protection provided by the equipment may be impaired.

⚠ ⚠ DANGER**HAZARD OF ELECTRIC SHOCK, EXPLOSION, OR ARC FLASH**

- Remove all power from the device before removing any covers or elements of the system, and prior to installing or removing any accessories, hardware, or cables.
- Unplug the power cable from both this product and the power supply prior to installing or removing the product.
- Always use a properly rated voltage sensing device to confirm power is off where and when indicated.
- Replace and secure all covers or elements of the system before applying power to this product.
- Use only the specified voltage when operating this product. The DC model is designed to use 12 to 24 Vdc, and the AC model is designed to use 100 to 240 Vac. Always check whether your device is DC or AC powered before applying power.
- When using this product in Class I, Division 2, Groups A, B, C, and D hazardous locations, install this product in an enclosure that prevents the operator from touching the back of this product without the use of tools.

Failure to follow these instructions will result in death or serious injury.

Critical alarm indicators and system functions require independent and redundant protection hardware and/or mechanical interlocks.

Please design a safety circuit external to this product so that the entire system operates safely even if the external power supply or this product fails or malfunctions.

- Interlocks and other circuits designed to interrupt or prevent equipment operation (such as emergency stops, protective circuits, and opposing action circuits) and circuits that prevent machine damage, such as positioning mechanisms, should be constructed external to the product.
- The product stops operation when it detects an abnormality such as a watchdog timer error. If an error occurs in the input/output control area, which cannot be monitored, it may lead to unexpected input/output behavior. Therefore, it is important to configure an external fail-safe circuit or mechanism.
- Problems with the relay or transistor in the output unit may cause the output to remain either in the ON or OFF state. Install an external monitoring circuit for output signals that may cause a serious accident.

Design the circuit so that power is supplied to the external device or load control power supply connected to this product before it starts.

When you cycle power, wait at least 10 seconds after it has been turned off. If this product is restarted too quickly, it may not operate correctly.

Do not create any switches on the touch panel that may cause personal injury, property damage, or compromise the safety of the equipment. Design the system so that controls for important operations are managed by devices other than this product, or by independent hardware switches.

In the event the screen cannot be properly read, for example, if the backlight is not functioning, it may be difficult or impossible to identify a function. Functions that may present a hazard if not immediately executed, such as a fuel shut-off, must be provided independently of this product.

▲ WARNING

LOSS OF CONTROL

- The designer of any control scheme must consider the potential failure modes of control paths and, for certain critical control functions, provide a means to achieve a safe state during and after a path failure. Examples of critical control functions are emergency stop and overtravel stop, power outage and restart.
- Separate or redundant control paths must be provided for critical control functions.
- System control paths may include communication links. Consideration must be given to the implications of unanticipated transmission delays or failures of the link.
- Observe all accident prevention regulations and local safety guidelines.
- Each implementation of this product must be individually and thoroughly tested for proper operation before being placed into service.
- The machine control system design must take into account the possibility of the backlight no longer functioning and the operator being unable to control the machine, or making errors in the control of the machine.

Failure to follow these instructions can result in death, serious injury, or equipment damage.

For additional information, refer to NEMA ICS 1.1 (latest edition), "Safety Guidelines for the Application, Installation, and Maintenance of Solid State Control" and to NEMA ICS 7.1 (latest edition), "Safety Standards for Construction and Guide for Selection, Installation and Operation of Adjustable-Speed Drive Systems" or their equivalent governing your particular location.

▲ WARNING

UNINTENDED EQUIPMENT OPERATION

- The application of this product requires expertise in the design and programming of control systems. Only persons with such expertise should be allowed to program, install, alter, and apply this product.
- Do not use this product as the only means of control for critical system functions such as motor start/stop or power control.
- Do not use this equipment as the only notification device for critical alarms, such as device overheating or overcurrent.
- Use only the software provided with this product. If you use other software, please confirm the operation and safety before use.
- Follow all applicable safety standard, local regulations and directives.

Failure to follow these instructions can result in death, serious injury, or equipment damage.

The following characteristics are specific to the LCD panel and are considered normal behavior:

- LCD screen may show unevenness in the brightness of certain images or may appear different when seen from outside the specified viewing angle. Extended shadows, or crosstalk may also appear on the sides of screen images.
- LCD screen pixels may contain black and white colored spots and color display may seem to have changed.
- When experiencing vibrations within a certain frequency range and vibration acceleration is above what is acceptable, the LCD screen may partially turn white. Once the vibration condition ends, the whitening of the screen is resolved.
- When the same image is displayed on the screen for a long period, an afterimage may appear when the image is changed.

- The panel brightness may decrease when used for a long time in an environment continuously filled with inert gas. To prevent deterioration of panel brightness, regularly ventilate the panel. For more information, please contact customer support.

<https://www.pro-face.com/trans/en/manual/1015.html>

▲ WARNING

SERIOUS EYE AND SKIN INJURY

The liquid in the LCD panel contains an irritant:

- Avoid direct skin contact with the liquid.
- Wear gloves when you handle a broken or leaking unit.
- Do not use sharp objects or tools in the vicinity of the LCD panel.
- Handle the LCD panel carefully to prevent puncture, bursting, or cracking of the panel material.
- If the panel is damaged and any liquid comes in contact with your skin, immediately rinse the area with running water for at least 15 minutes. If the liquid gets in your eyes, immediately rinse your eyes with running water for at least 15 minutes and consult a doctor.

Failure to follow these instructions can result in death, serious injury, or equipment damage.

NOTICE

REDUCED SERVICE LIFE

Change the screen image periodically and try not to display the same image for a long period of time.

Failure to follow these instructions can result in equipment damage.

Precautions on using models with projected capacitive touch panel

Models with a projected capacitive (PCAP) touch panel may operate abnormally when the display surface is wet.

▲ WARNING

LOSS OF CONTROL

- Do not touch the touch panel area during operating system startup.
- Do not operate when the touch panel surface is wet.
- If the touch panel surface is wet, remove any excess water with a soft cloth before operation.

Failure to follow these instructions can result in death, serious injury, or equipment damage.

NOTE:

- When **Touch Mode** is set to **Water detection mode**, an abnormal touch (such as accidental contact with water or other liquids) will temporarily disable touch for a few seconds to avoid unintended operations. Normal touch operation recovers a few seconds after the abnormal touch condition is removed. You can change the **Touch Mode** in **System Settings**.
- While the system is starting up, as the touch panel initial values are being checked, do not touch the touch panel area.

NOTICE

EQUIPMENT DAMAGE

- Do not press on the display of this product with excessive force or with a hard object.
- Do not press on the touch panel with a pointed object, such as the tip of a mechanical pencil or a screwdriver.
- Handle this product carefully to prevent puncture, bursting, or cracking of the panel material.

Failure to follow these instructions can result in equipment damage.

Compared to conventional analog resistive film, projected capacitive touch panels have higher transmittance and lighter touch operation, as well as supporting multi-touch. As it is able to detect weak changes in capacitance, projected capacitive touch panels are susceptible to environmental noise.

While our products have been optimized for industrial environmental noise and conform to CE marking, our products cannot support all environmental noise.

Please consider the following in the installation environment to avoid touch malfunction.

Example:

To reduce the noise voltage of the enclosure of the equipment housing this product:

- Implement noise countermeasures in the equipment. For example, install a noise filter on the inverter, servo amplifier, or other equipment. Refer to the manufacturer's instruction manual.
- Attach a ground wire noise filter to the FG connection of equipment.
- Connect the enclosure for the equipment to the building. For example, connect to the concrete or steel reinforcement parts of the building.

NOTE: If there is a lot of environmental noise, because the noise filter for the touch panel controller has to run, touch response may become slow.

General Cybersecurity Information

In recent years, the growing number of networked machines and production plants has seen a corresponding increase in the potential for cyber threats, such as unauthorized access, data breaches, and operational disruptions. You must, therefore, consider all possible cybersecurity measures to help protect assets and systems against such threats.

To help keep your Pro-face products secure and protected, it is in your best interest to implement the cybersecurity best practices as described in the [Cybersecurity Best Practices](#) document.

Pro-face provides additional information and assistance:

- Visit the [Security Notification](#) page to find security notifications.
- [Contact us](#) to report vulnerabilities and incidents.

Product Related Cybersecurity Information

Refer to [Cybersecurity](#), page 13.

Environmental Data

For product compliance and environmental information, refer to the Pro-face Environmental Data Program.

Available Languages of the Document

The document is available in these languages:

- English (GP6000-MM01-EN)
- French (GP6000-MM01-FR)
- German (GP6000-MM01-DE)
- Spanish (GP6000-MM01-ES)
- Italian (GP6000-MM01-IT)
- Chinese (GP6000-MM01-CS)
- Japanese (GP6000-MM01-JA)
- Korean (GP6000-MM01-KO)

Related Documents

Title of documentation	Reference number
Cybersecurity Best Practices	Refer to General Cybersecurity Information, page 10.
HMI/IPC Cybersecurity Guide	PFHMIIPCCS-MM01-EN (ENG) PFHMIIPCCS-MM01-JA (JPN)
GP6000 Series System Settings User Guide	English (GP6000-SYS-MM01-EN) French (GP6000-SYS-MM01-FR) German (GP6000-SYS-MM01-DE) Spanish (GP6000-SYS-MM01-ES) Italian (GP6000-SYS-MM01-IT) Chinese (GP6000-SYS-MM01-CS) Japanese (GP6000-SYS-MM01-JA) Korean (GP6000-SYS-MM01-KO)
Expansion Unit Hardware Guide	English (EXZH-MM01-EN) French (EXZH-MM01-FR) German (EXZH-MM01-DE) Spanish (EXZH-MM01-ES) Italian (EXZH-MM01-IT) Chinese (EXZH-MM01-CS) Japanese (EXZH-MM01-JA) Korean (EXZH-MM01-KO)

You can download the manuals related to this product, such as the software manual, from the Pro-face download page (www.pro-face.com/trans/en/manual/1085.html).

Information on Non-Inclusive or Insensitive Terminology

As a responsible, inclusive company, Schneider Electric is constantly updating its communications and products that contain non-inclusive or insensitive terminology. However, despite these efforts, our content may still contain terms that are deemed inappropriate by some customers.

Trademarks

Microsoft® and Windows® are registered trademarks of Microsoft Corporation in the United States and/or other countries.

QR Code is a registered trademark of DENSO WAVE INCORPORATED in Japan and other countries.

Product names used in this manual may be the registered trademarks owned by the respective proprietors.

Cybersecurity

Cybersecurity Guideline

Use this product inside a secure industrial automation and control system. Total protection of components (equipment/devices), systems, organizations, and networks from cyber attack threats requires multi-layered cyber risk mitigation measures, early detection of incidents, and appropriate response and recovery plans when incidents occur. For more information about cybersecurity, refer to the Pro-face HMI/IPC Cybersecurity Guide.

https://www.proface.com/en/download/manual/cybersecurity_guide

▲ WARNING
<p>POTENTIAL COMPROMISE OF SYSTEM AVAILABILITY, INTEGRITY, AND CONFIDENTIALITY</p> <ul style="list-style-type: none"> • Change default passwords at first use to help prevent unauthorized access to device settings, controls and information. • Disable unused ports/services and default accounts, where possible, to minimize pathways for malicious attacks. • Place networked devices behind multiple layers of cyber defenses (such as firewalls, network segmentation, and network intrusion detection and protection). • Apply the latest updates and hotfixes to your Operating System and software. • Use cybersecurity best practices (for example: least privilege, separation of duties) to help prevent unauthorized exposure, loss, modification of data and logs, interruption of services, or unintended operation. <p>Failure to follow these instructions can result in death, serious injury, or equipment damage.</p>

Security Seal

This product has a security seal attached, which helps detect unauthorized repairs or modifications to the product. Once the security seal is removed, it cannot be reapplied, increasing the product's security risk.

▲ WARNING
<p>POTENTIAL COMPROMISE OF SYSTEM AVAILABILITY, INTEGRITY, AND CONFIDENTIALITY</p> <ul style="list-style-type: none"> • Do not remove the security seal on the product. • Do not use products with removed security seals. <p>Failure to follow these instructions can result in death, serious injury, or equipment damage.</p>

Overview

What's in This Chapter

Model Numbers.....	14
Package Contents.....	15
Certifications and Standards.....	17
Federal Communication Commission Radio Frequency Interference Statement - For USA.....	18
Hazardous Location Installation - For USA and Canada.....	19

Model Numbers

Model List

Series		Display size	Model number
GP6000 Series (Advanced Model)	Panel mount type	10-inch	PFXGP6540TMAI PFXGP6540TMDI
		10-inch wide	PFXGP6540WCAI PFXGP6540WCDI
		12-inch	PFXGP6640TMAI PFXGP6640TMDI
		12-inch wide	PFXGP6640WCAI PFXGP6640WCDI
		15-inch	PFXGP6740TMAI PFXGP6740TMDI
		15-inch wide	PFXGP6740WCAI PFXGP6740WCDI
		19-inch wide	PFXGP6840WCAI PFXGP6840WCDI
	22-inch wide	PFXGP6940WCAI PFXGP6940WCDI	
	DIN mount type	-	PFXGP6B40AI PFXGP6B40DI

NOTE: All model numbers may be followed by any letter or number.

Model Number Configuration

The following describes the configuration of model numbers.

Digit	Category	Number	Description
1...3	(Prefix)	PFX	-
4...6	Series	GP6	-
7	Display size	5	10"
		6	12"
		7	15"
		8	19"
		9	22"
		B	No display (DIN mount type)
8, 9	Type	40	Advanced

Digit	Category	Number	Description
10	LCD	T	TFT
		W	Wide TFT
		(none)*1	No display (DIN mount type)
11	Touch panel	C	PCAP (multi-touch)
		M	Analog (multi-touch)
		(none)*1	No display (DIN mount type)
12	Power supply	A	AC
		D	DC
13 and later	Supported software, others	I	GP-Pro EX

*1 The digit is skipped if it does not have the corresponding identification number.

Package Contents

Package Contents (Panel Mount Type)

Verify all items listed here are present in your package.

If you find anything damaged or missing, please contact customer support immediately.

▲WARNING

UNINTENDED EQUIPMENT OPERATION

Do not use damaged products or accessories.

Failure to follow these instructions can result in death, serious injury, or equipment damage.

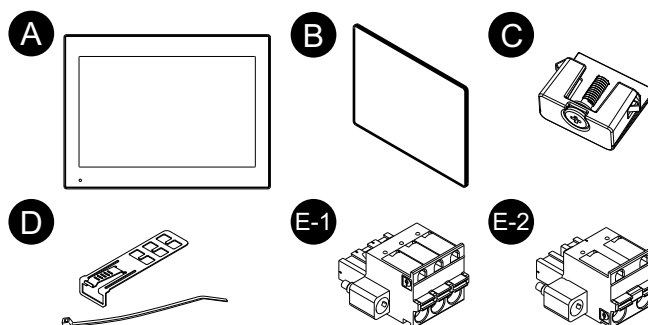

- A. GP6000 Series Advanced Model x 1
- B. Installation gasket (attached to this product) x 1
- C. Installation fasteners (to install on a panel)
 - 4 pieces (for 10-inch, 12-inch, 10-inch wide and 12-inch wide models)
 - 8 pieces (for 15-inch, 15-inch wide, 19-inch wide and 22-inch wide models)
- D. USB cable clamp (Type-A) x 2 set (2 clips and 2 ties)
- E. Power connector x 1 (E-1 for DC, E-2 for AC)
- F. Instruction sheet x 1

Package Contents (DIN Mount Type)

Verify all items listed here are present in your package.

If you find anything damaged or missing, please contact customer support immediately.

▲ WARNING

UNINTENDED EQUIPMENT OPERATION

Do not use damaged products or accessories.

Failure to follow these instructions can result in death, serious injury, or equipment damage.

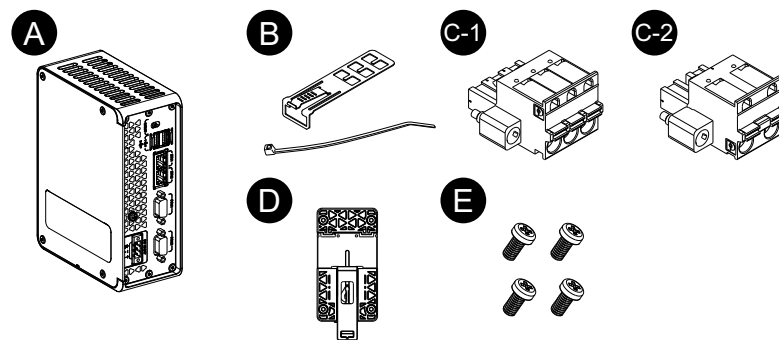

- A. GP6000 Series Advanced Model x 1
- B. USB cable clamp (Type-A) x 2 set (2 clips and 2 ties)
- C. Power connector x 1 (C-1 for DC, C-2 for AC)
- D. DIN rail attachment x 1
- E. M4 screw (length: 10 mm [0.39 in])*1 x 4
- F. Instruction sheet x 1

*1 These screws are used to attach the DIN rail attachment to the product.

Product Revision and QR Code

You can identify the product version (PV) and the software version (SV) from the product label.

You can also check the contents of this manual by using the QR code on the product label. Confirm the location of the QR code below and refer to the manual.

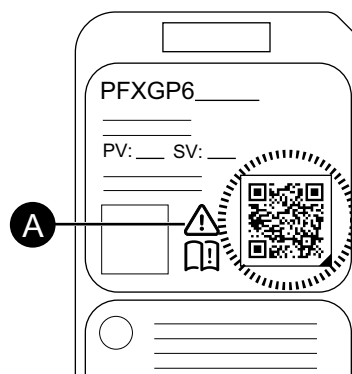

- A. This mark indicates that you can refer to this manual by using the QR code, and that you must use copper wire rated for 75 °C (167 °F) or higher. Refer to Wiring the Power Supply, page 74.

Certifications and Standards

The certifications and standards listed below may include those that are not yet acquired. Please check the product marking and the following URL for the latest acquisition status.

<https://www.pro-face.com/trans/en/manual/1002.html>

Agency Certifications

All models

- Underwriters Laboratories LLC., UL 61010-2-201 and CSA C22.2 N°61010-2-201, for Industrial Control Equipment used in Ordinary Locations

Only DC models

- Underwriters Laboratories LLC., UL 121201 and CSA C22.2 N°213, for Industrial Control Equipment used in Class I, Division 2 Hazardous (Classified) Locations
- IECEx / ATEX for use in zone 2 gas /zone 22 dust
- CCCEX
- KCs
- EU RO Mutual Recognition (EU RO MR) following IACS UR E10
- China Classification Society (CCS)
- Det Norske Veritas (DNV)
- Nippon Kaiji Kyokai (NK)

Compliance Standards

Europe:

CE/UKCA

- Directive 2014/35/EU (Low Voltage)
- Directive 2014/30/EU (EMC)
- Directive 2014/34/EU (ATEX)

Australia, New Zealand:

- RCM

Korea:

- KC

Hazardous Substances

This product is designed to be compliant with the following environmental regulations, even if the product may not fall directly in the scope of the regulation:

- RoHS, Directive 2011/65/EU and 2015/863/EU
- RoHS China, Standard GB/T 26572
- REACH regulation EC 1907/2006

End of Life (WEEE)

The product contains electronic boards. It must be disposed of in specific treatment channels. The product contains cells and/or storage batteries which

must be collected and processed separately when they have run out and at the end of product life (Directive 2012/19/EU).

Refer to *Maintenance*, page 93 when extracting cells and batteries from the product. These batteries do not contain a weight percentage of heavy metals over the threshold notified by European Battery Regulation 2023/1542.

KC Markings

기종별	사용자안내문
A급 기기 (업무용 방송통신기자재)	이 기기는 업무용(A급) 전자파적합기기로서 판매자 또는 사용자는 이 점을 주의하시기 바라며, 가정외의 지역에서 사용하는 것을 목적으로 합니다.

Federal Communication Commission Radio Frequency Interference Statement - For USA

FCC Radio Interference Information

This product has been tested and found to comply with the Federal Communications Commission (FCC) limits for a Class A digital device, pursuant to Part 15 of the FCC Rules. These limits are designed to provide reasonable protection against harmful interference in a commercial, industrial or business environment. This product generates, uses, and can radiate radio frequency energy and, if not installed and used in accordance with the instructions, may cause or be subject to interference with radio communications. To minimize the possibility of electromagnetic interference in your application, observe the following two rules:

- Install and operate this product in such a manner that it does not radiate sufficient electromagnetic energy to cause interference in nearby devices.
- Install and test this product to ensure that the electromagnetic energy generated by nearby devices does not interfere with the operation of this product.

▲ WARNING
<p>ELECTROMAGNETIC / RADIO INTERFERENCE, UNINTENDED EQUIPMENT OPERATION</p> <p>Check for electromagnetic and radio interference. If interference is detected, take the following actions.</p> <ul style="list-style-type: none"> • Increase the distance between this product and the interfering equipment. • Reorient this product and the interfering equipment. • Reroute power and communication lines to this product and the interfering equipment. • Connect this product and the interfering equipment to different power supplies. • Always use shielded cables when connecting this product to a peripheral device or another computer. <p>Failure to follow these instructions can result in death, serious injury, or equipment damage.</p>

Changes or modifications not expressly approved by the party responsible for compliance could void the user's authority to operate this product.

Hazardous Location Installation - For USA and Canada

General

This product is suitable for use in Class I, Division 2, Groups A, B, C, and D hazardous locations or in non-hazardous locations. Before installing or using this product, confirm that the Hazardous Location certification appears on the product labeling.

NOTE: Some products are not yet rated as suitable for use in hazardous locations. Always use your product in conformance with the product labeling and this manual.

DANGER

HAZARD OF ELECTRIC SHOCK, EXPLOSION, OR ARC FLASH

- Remove all power from the device before removing any covers or elements of the system, and prior to installing or removing any accessories, hardware, or cables.
- Unplug the power cable from both this product and the power supply prior to installing or removing the product.
- Always use a properly rated voltage sensing device to confirm power is off where and when indicated.
- Replace and secure all covers or elements of the system before applying power to this product.
- Use only the specified voltage when operating this product. The DC model is designed to use 12 to 24 Vdc, and the AC model is designed to use 100 to 240 Vac. Always check whether your device is DC or AC powered before applying power.

Failure to follow these instructions will result in death or serious injury.

⚠ WARNING

EXPLOSION HAZARD

- Do not use this product in hazardous environments or locations other than Class I, Division 2, Groups A, B, C, and D.
- Substitution of any components may impair suitability for Class I, Division 2.
- Always confirm the UL 121201 or CSA C22.2 No.213 hazardous location rating of your device before installing or using it in a hazardous location.
- To apply or remove the supply power from this product installed in a Class I, Division 2 hazardous location, you must either: A) Use a switch located outside the hazardous environment, or B) Use a switch certified for Class I, Division 1 operation inside the hazardous area.
- Do not connect or disconnect equipment unless power has been switched off or the area is known to be non-hazardous. This applies to all connections including power, ground, serial, parallel, and network connections.
- Do not install any components, equipment, or accessories manufactured by us or by OEM unless these have also been qualified as suitable for use in Class I, Division 2, Groups A, B, C, and D locations.
- Always use shielded/grounded cables in hazardous locations.
- Use only non-incendive USB devices.
- Do not attempt to install, operate, modify, maintain, service, or otherwise alter this product except as permitted in this manual. Unpermitted actions may impair the suitability of this product for Class I, Division 2 operation.

Failure to follow these instructions can result in death, serious injury, or equipment damage.

Make sure that this product is properly rated for the location. If the intended location does not presently have a Class, Division and Group rating, then users should consult the appropriate authorities having jurisdiction in order to determine the correct rating for that hazardous location.

Operation and Maintenance

The systems have been designed for compliance with relevant spark ignition tests.

⚠ WARNING

EXPLOSION HAZARD

In addition to the other instructions in this manual, observe the following rules when installing this product in a hazardous location:

- Wire the equipment in accordance with the National Electrical Code article 501.10 (B) for Class I, Division 2 hazardous locations.
- Install this product in an enclosure suitable for the specific application.

Failure to follow these instructions can result in death, serious injury, or equipment damage.

Device Connectivity

What's in This Chapter

System Design.....21
 Accessories23

System Design

System Design (Panel Mount Type)

This section describes the system configuration with this product and peripheral equipment.

NOTE:

- The number of interfaces may vary depending on the model. Refer to Parts Identification and Functions, page 27.
- External storage devices used with this product should be formatted with the FAT, FAT32, or exFAT file system.
- When powering up the product for the first time, initial setup is required. For information on configuring the product, refer to the **System Settings** User Guide. The manuals for this product are listed in Related Documents, page 11.

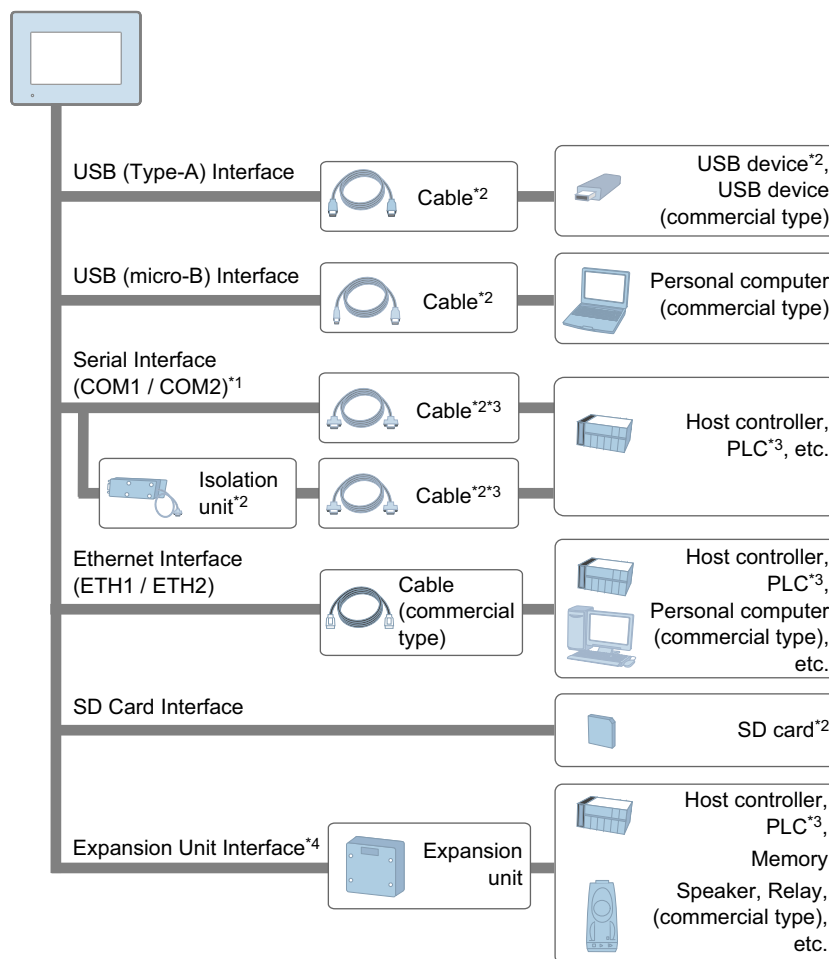

*1 The isolation unit can only be installed on the COM1 port. To use the isolation unit, set the pin 9 of the COM1 port to VCC.

*2 Refer to Accessories, page 23.

*3 For information on how to connect controllers and other types of equipment, refer to the corresponding device driver manual of your screen editing software.

*4 Up to two expansion units can be connected. For details, refer to Expansion Unit Hardware Guide.

System Design (DIN Mount Type)

This section describes the system configuration with this product and peripheral equipment.

NOTE:

- The number of interfaces may vary depending on the model. Refer to Parts Identification and Functions, page 27.
- External storage devices used with this product should be formatted with the FAT, FAT32, or exFAT file system.
- When powering up the product for the first time, initial setup is required. For information on configuring the product, refer to the **System Settings** User Guide. The manuals for this product are listed in Related Documents, page 11.

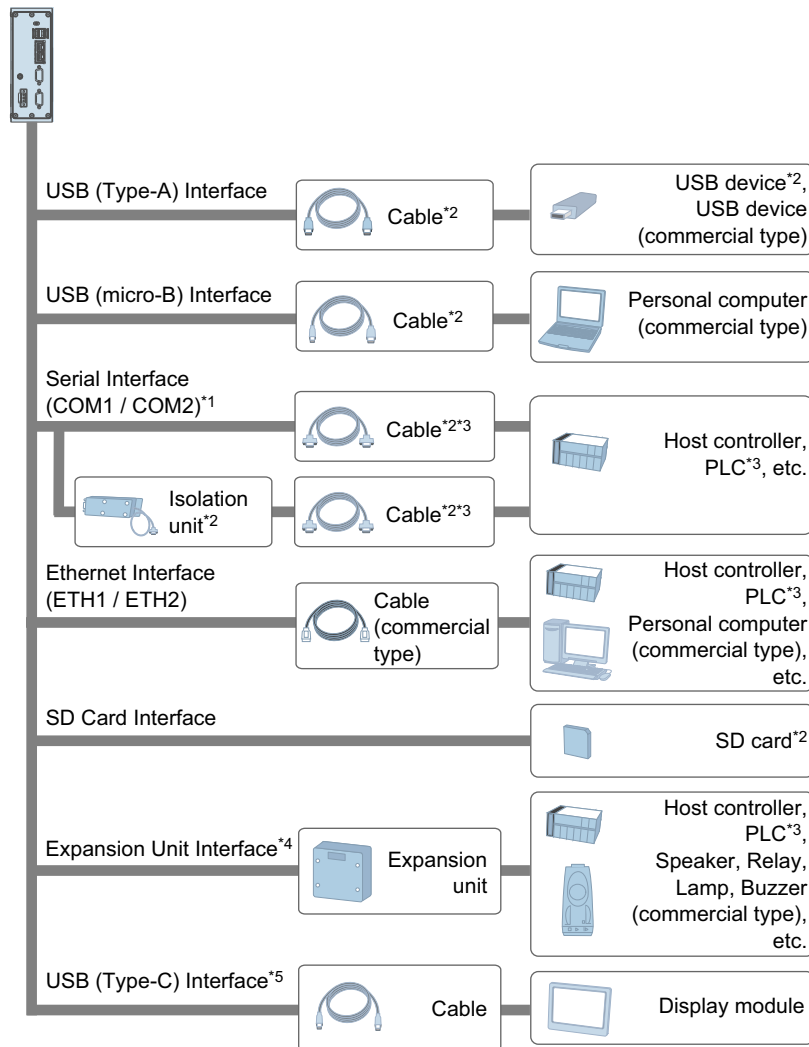

*1 The isolation unit can only be installed on the COM1 port. To use the isolation unit, set the pin 9 of the COM1 port to VCC.

*2 Refer to Accessories, page 23.

*3 For information on how to connect controllers and other types of equipment, refer to the corresponding device driver manual of your screen editing software.

*4 Up to five expansion units can be connected. For details, refer to Expansion Unit Hardware Guide.

*5 The USB (Type-C) interface supports DisplayPort Alternate Mode. By connecting one of our available panel displays with a dedicated cable, you can use it as an expansion display. Please check our website for available panel displays. Commercial displays and other USB (Type-C) devices cannot be connected.

Accessories

This section introduces optional items that are sold separately.

Products may change or be discontinued without notice. Please check our website for the latest information.

<https://www.pro-face.com>

For host controllers and connection cables, refer to the corresponding device driver manual of your screen editing software.

Product name	Product number	Description
Serial Interface		
9-pin to 25-pin RS-232C Conversion Cable (0.2 m)	PFXZC3CBCVR21	Cable for converting a D-Sub 9-pin plug to a D-Sub 25-pin socket (RS-232C). (0.2 m [0.66 ft])
RS-422 9/25-pin Conversion Cable (0.2 m)	PFXZCBCBCVR41	Cable for converting a D-Sub 9-pin plug to a D-Sub 25-pin socket (RS-422). (0.2 m [0.66 ft])
RS-422 Terminal Block Conversion Adapter	PFXZCBADTM1	Connects output from a serial interface (D-Sub 9 pin plug) directly to an RS-422 terminal block.
Terminal Block Conversion Adapter	PFXZC3ADR41	Connects output from a serial interface with an RS-422 terminal block.
RS-232C Isolation Unit	PFXZC3ADISR21	Connects a host controller to this product and provides isolation (RS-232C and RS-422 are switchable).
COM Port Conversion Adapter	PFXZC3ADCM1	Connects optional RS-422 communication items to serial interface.
USB (micro-B) Interface		
USB Transfer Cable	PFXZUSCBMB2	Cable for transferring screen data from a PC (USB Type-A) to this product (USB micro-B).
USB (micro-B) Front Cable	PFXZCIEXMB2	Extension cable that attaches USB interface to front panel.
USB (Type-A) Interface		
USB Front Cable (1 m)	PFXZC5CBUBEX1	Extension cable that attaches USB interface to front panel.
Enhanced front USB cover (with screw) ^{*1}	PFXZCDCVUS1	Front USB cover with fixing screw, corresponding to IP66F, IP67F, Type 1/4X Indoor use only /13 or ATEX certifications (5 pieces/set).
USB (Type-C) Interface		
USB Type-C Cable (5 m)	HMIZCUSBC5	Connects to our panel display with a USB Type-C port that supports DisplayPort Alternate Mode.
Expansion Unit Interface		

Product name	Product number	Description
Serial Interface Expansion Unit	PFXZHMUSIO1	Module for expanding the serial interface to this product. RS-232C/422/485 x 1 (D-Sub 9 pin plug), RS-485 isolation x 1 (D-Sub 9 pin socket).
Ethernet Interface Expansion Unit	PFXZHETH1	Module for expanding the Ethernet interface. Switching hub, 4-port.
AUX Interface Expansion Unit	PFXZHMUAUX1	AUX interface module. AUX connector (1 piece) is included.
Backup Memory Expansion Unit	PFXZHMUEM1	Module for adding up to 2 MB of backup memory.
SD Card Interface		
SD Memory Card	PFXZCBSD4GC41	SD memory card (4 GB), SDHC
	PFXZCSD16GC101	SD memory card (16 GB, pSLC), SDHC
	PFXZCSD32GC101	SD memory card (32 GB, pSLC), SDHC
	PFXYP6SD64GCX	SD memory card (64 GB), SDXC
Others		
Screen Protection Sheet	PFXZCBDS101	Disposable, dirt-resistant sheet for 10.4-inch screen (5 sheets/set).
	PFXZC7DS121	Disposable, dirt-resistant sheet for 12.1-inch screen (5 sheets/set).
	PFXZC3DS151	Disposable, dirt-resistant sheet for 15-inch screen (5 sheets/set).
UV Protection Sheet	PFXZCFUV101	Sheet to protect the display from ultraviolet light, for 10-inch screen (1 sheet).
Environment Cover	PFXZCDOP101	Disposable, environmental resistant cover for 10-inch screen (1 sheet).
	PFXZCDOP121	Disposable, environmental resistant cover for 12-inch screen (1 sheet).
	PFXZCDOP151	Disposable, environmental resistant cover for 15-inch screen (1 sheet).
Anti-glare Sheet	PFXZCAG5W1	Prevent reflections, dirt-resistant sheet for 10-inch wide display (5 sheets/set).
	PFXZCAG6W1	Prevent reflections, dirt-resistant sheet for 12-inch wide display (5 sheets/set).
	PFXZCAG7W1	Prevent reflections, dirt-resistant sheet for 15-inch wide display (5 sheets/set).
	PFXZCAG8W1	Prevent reflections, dirt-resistant sheet for 19-inch wide display (5 sheets/set).
	PFXZCAG9W1	Prevent reflections, dirt-resistant sheet for 22-inch wide display (5 sheets/set).
Panel Cutout Adapter ²	PFXZC4AT101	Panel cutout adapter for mounting 10-inch model in cutout for GP-2500/2600 Series, AGP-3500L/AGP-3500S/AGP-36*0T/AGP-36*0U.
	PFXZHAT7W1	Panel cutout adapter for mounting 15-inch wide model in cutout for SP-5700WC.
	PFXZHAT8W1	Panel cutout adapter for mounting 19-inch wide model in cutout for SP-5800WC.

Product name	Product number	Description
VESA Mounting Plate	HMIZHVESA	VESA mounting bracket.

*1 Supported by 12-inch and 15-inch models only.

*2 The range for the allowable panel thickness varies depending on the panel cutout adapter. For information, refer to the panel cutout adapter instruction sheet.

Maintenance Accessories

This section lists replacement parts.

Product name	Product number	Description
Box Module		
Box Module (DC)*1	PFXGP6Z40DI	Box module (DC model) for GP6000 Series Advanced Model (panel mount type).
Box Module (AC)*1	PFXGP6Z40AI	Box module (AC model) for GP6000 Series Advanced Model (panel mount type).
Display Module		
10-inch Display Module	PFXDM6500TM	10-inch display module with front USB port, SVGA, 16 M colors, analog multi-touch.
12-inch Display Module	PFXDM6600TM	12-inch display module with front USB port, XGA, 16 M colors, analog multi-touch.
15-inch Display Module	PFXDM6700TM	15-inch display module with front USB port, XGA, 16 M colors, analog multi-touch.
10-inch Wide Display Module	PFXDM6500WC	10-inch wide display module, WXGA, 16 M colors, projected capacitive multi-touch.
12-inch Wide Display Module	PFXDM6600WC	12-inch wide display module, WXGA, 16 M colors, projected capacitive multi-touch.
15-inch Wide Display Module	PFXDM6710WC	15-inch wide display module, full HD, 16 M colors, projected capacitive multi-touch.
19-inch Wide Display Module	PFXDM6800WC	19-inch wide display module, full HD, 16 M colors, projected capacitive multi-touch.
22-inch Wide Display Module	PFXDM6900WC	22-inch wide display module, full HD, 16 M colors, projected capacitive multi-touch.
Installation Fastener		
Installation Fastener	PFXZCAF1	Fastener for installing the product into a solid panel (4 pieces/set).
Installation Gasket		
Installation Gasket for 10-inch	PFXZCDWG101	Provides dust and moisture resistance when 10-inch model is installed into a solid panel (1 piece).
Installation Gasket for 12-inch	PFXZCDWG121	Provides dust and moisture resistance when 12-inch model is installed into a solid panel (1 piece).
Installation Gasket for 15-inch	PFXZCDWG151	Provides dust and moisture resistance when 15-inch model is installed into a solid panel (1 piece).
Installation Gasket for 10-inch wide	PFXZCDWG102	Provides dust and moisture resistance when 10-inch wide model is installed into a solid panel (1 piece).

Product name	Product number	Description
Installation Gasket for 12-inch wide	PFXZCDWG122	Provides dust and moisture resistance when 12-inch wide model is installed into a solid panel (1 piece).
Installation Gasket for 15-inch wide	PFXZCHWG154	Provides dust and moisture resistance when 15-inch wide model is installed into a solid panel (1 piece).
Installation Gasket for 19-inch wide	PFXZCWG8W1	Provides dust and moisture resistance when 19-inch wide model is installed into a solid panel (1 piece).
Installation Gasket for 22-inch wide	PFXZCWG9W1	Provides dust and moisture resistance when 22-inch wide model is installed into a solid panel (1 piece).
Power Supply Connector		
Power Connector (DC)	PFXZC7CNACL1	Connector with fixable screws to connect DC power supply cables (Straight type, 5 pieces/set).
Power Connector (AC)	PFXZCCNAC1	Connector with fixable screws to connect AC power supply cable (Straight type, 5 pieces/set).
USB Cable Clamp		
USB Clamp Type-A (1 port)	PFXZCBCLUSA1	Clamp to prevent disconnection of USB cable (USB Type-A, 1 port, 5 clamps/set).

*1 The ambient air temperature of the Box Module is determined by the Display Module it is installed in. For details, refer to [Environmental Specifications \(Panel Mount Type\)](#), page 39.

Parts Identification and Functions

What's in This Chapter

Parts Identification (Panel Mount Type).....	27
LED Indications (Panel Mount Type).....	31
Parts Identification (DIN Mount Type).....	32
LED Indications (DIN Mount Type).....	34

Parts Identification (Panel Mount Type)

Parts Identification (10, 12, 15-inch Model)

NOTE: The figures below show the 12-inch model.

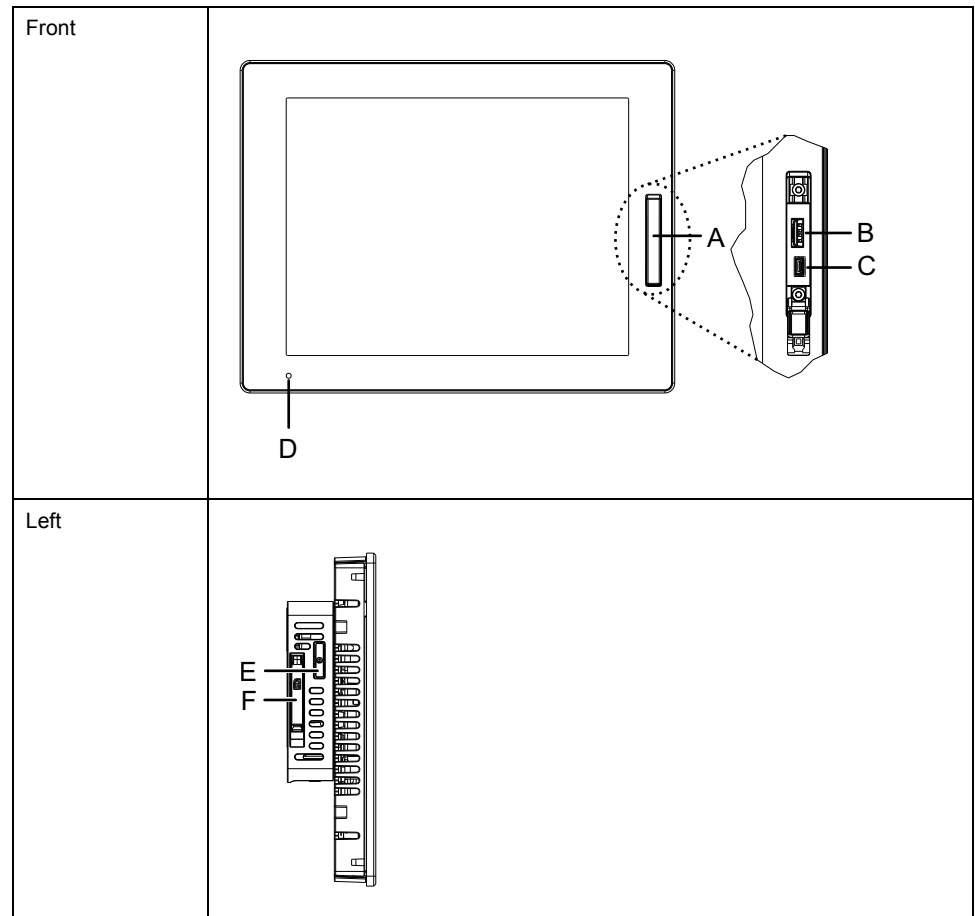

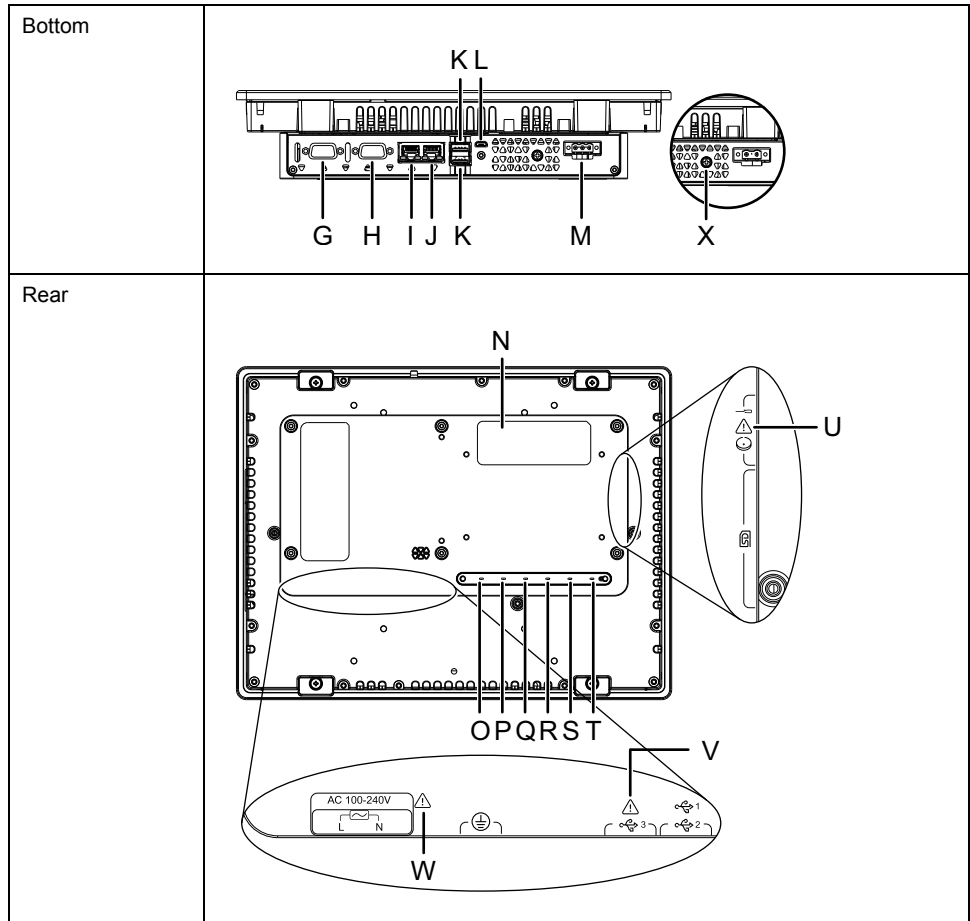

- | | |
|------------------------------------|--|
| A. Front USB cover | M. Power connector |
| B. Front USB (Type-A) interface*1 | N. Expansion unit interface*3 |
| C. Front USB (micro-B) interface*1 | O. Status LED (STA) |
| D. Status LED (front LED) | P. Error LED (ERR) |
| E. Battery slot | Q. COM1 LED (COM1) |
| F. SD card slot cover | R. COM2 LED (COM2) |
| G. Serial interface (COM2) | S. USB storage LED (USB) |
| H. Serial interface (COM1) | T. SD card access LED (SD) |
| I. Ethernet interface (ETH2)*2 | U. Safety alert symbol*4 |
| J. Ethernet interface (ETH1) | V. Safety alert symbol*5 |
| K. USB (Type-A) interface (x 2) | W. Safety alert symbol (AC model only)*6 |
| L. USB (micro-B) interface | X. PE terminal (used for AC model only) |

*1 The factory default for the Front USB ports (Type-A and micro-B) is disabled. To enable it, change the setting in the **System Settings**. For details, refer to GP6000 Series System Settings User Guide.

*2 The factory default for the ETH2 port is disabled. Use the **System Settings** to change it. For details, refer to GP6000 Series System Settings User Guide.

*3 There is an Expansion unit interface connector under the label. Remove the label only when installing the expansion unit to the product. For instructions on installing the expansion unit, refer to Expansion Unit Hardware Guide.

*4 Identifies the safety messages about the battery in Replacing the Battery, page 97.

*5 Identifies the safety messages about the USB (micro-B) interface in Cable Connections, page 48.

*6 Identifies the safety messages about the power wiring in Wiring the Power Supply, page 74.

Parts Identification (10, 12, 15, 19, 22-inch Wide Model)

NOTE: The figures below show the 15-inch wide model.

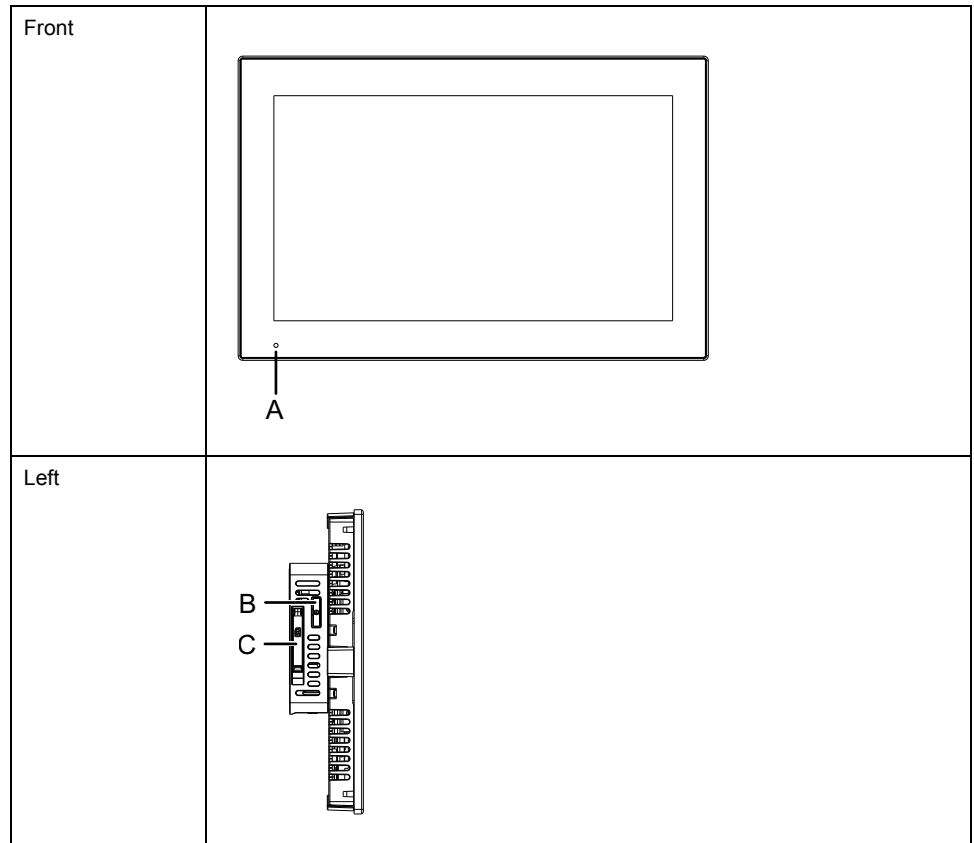

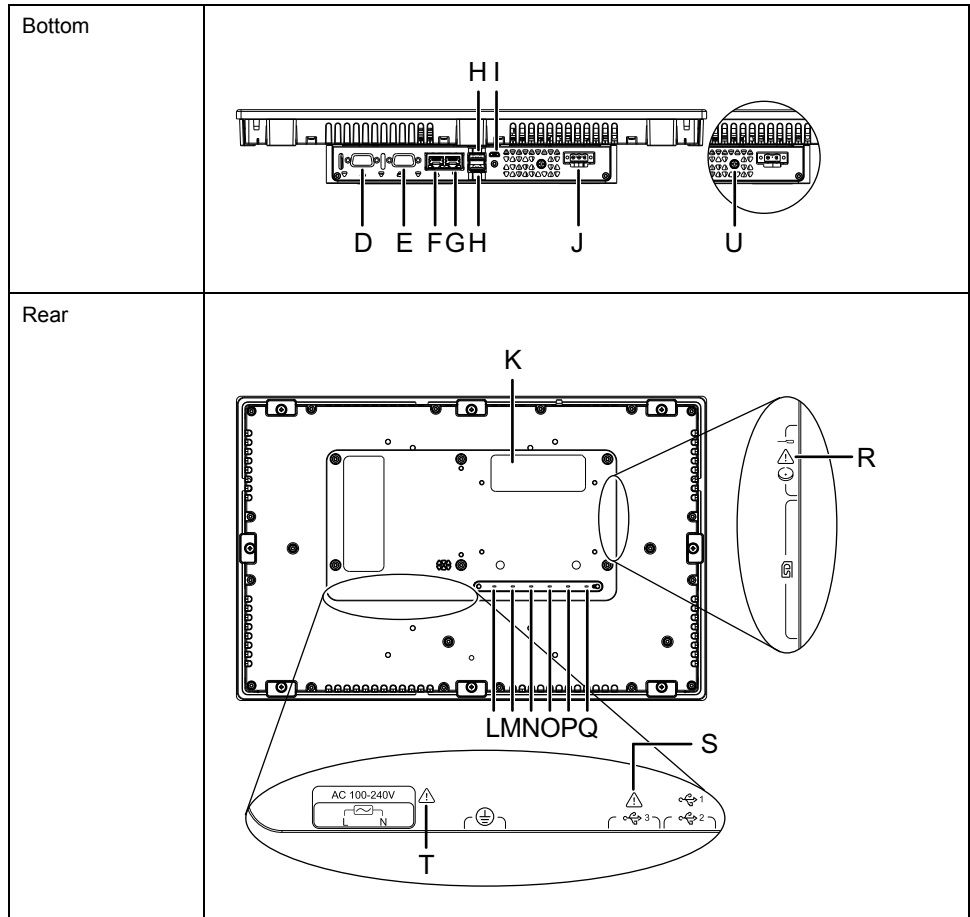

- A. Status LED (front LED)
- B. Battery slot
- C. SD card slot cover
- D. Serial interface (COM2)
- E. Serial interface (COM1)
- F. Ethernet interface (ETH2)*1
- G. Ethernet interface (ETH1)
- H. USB (Type-A) interface (x 2)
- I. USB (micro-B) interface
- J. Power connector
- K. Expansion unit interface*2
- L. Status LED (STA)
- M. Error LED (ERR)
- N. COM1 LED (COM1)
- O. COM2 LED (COM2)
- P. USB storage LED (USB)
- Q. SD card access LED (SD)
- R. Safety alert symbol*3
- S. Safety alert symbol*4
- T. Safety alert symbol (AC model only)*5
- U. PE terminal (used for AC model only)

*1 The factory default for the ETH2 port is disabled. Use the **System Settings** to change it. For details, refer to GP6000 Series System Settings User Guide.

*2 There is an Expansion unit interface connector under the label. Remove the label only when installing the expansion unit to the product. For instructions on installing the expansion unit, refer to Expansion Unit Hardware Guide.

*3 Identifies the safety messages about the battery in Replacing the Battery, page 97.

*4 Identifies the safety messages about the USB (micro-B) interface in Cable Connections, page 48.

*5 Identifies the safety messages about the power wiring in Wiring the Power Supply, page 74.

LED Indications (Panel Mount Type)

Status LED (Front LED)

After the power is turned on, the normal status indication by the LED is: red light > blinking orange > green light.

Color	Indicator	HMI operation
Green	ON	In operation/Offline
	Blinking (ON/OFF every 3 seconds)	Backlight OFF (Standby Mode)
Orange	Blinking	Software starting up
Red	ON	Power is ON.
-	OFF	Power is OFF.

For other LED indications, refer to the manual of your screen editing software.

Ethernet LED

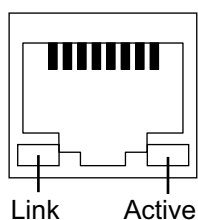

Color	Indicator	Description
Green (Link)	ON	Data transmission is available.
	OFF	No connection or error
Green (Active)	Blinking	Data transmission in progress
	ON	No data transmission
	OFF	No connection or error

Rear LEDs

The status LED indicators on the rear of the product are the same as the front LED. Please refer to [Status LED \(Front LED\)](#), page 31.

The LED indicators for Error, COM1/COM2, USB storage, and SD card access are the same as those for the DIN mount type. Please refer to [LED Indications \(DIN Mount Type\)](#), page 34.

Parts Identification (DIN Mount Type)

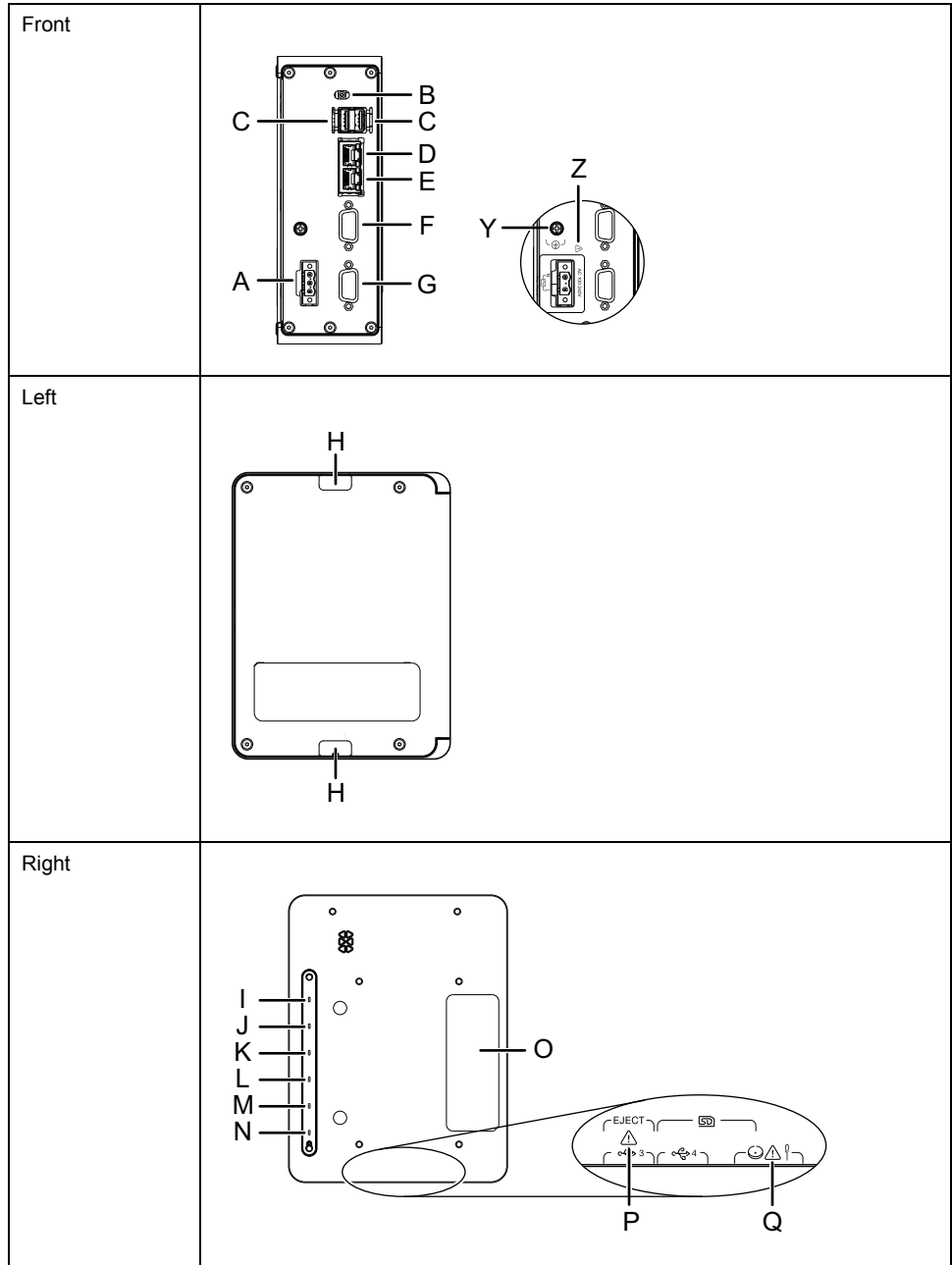

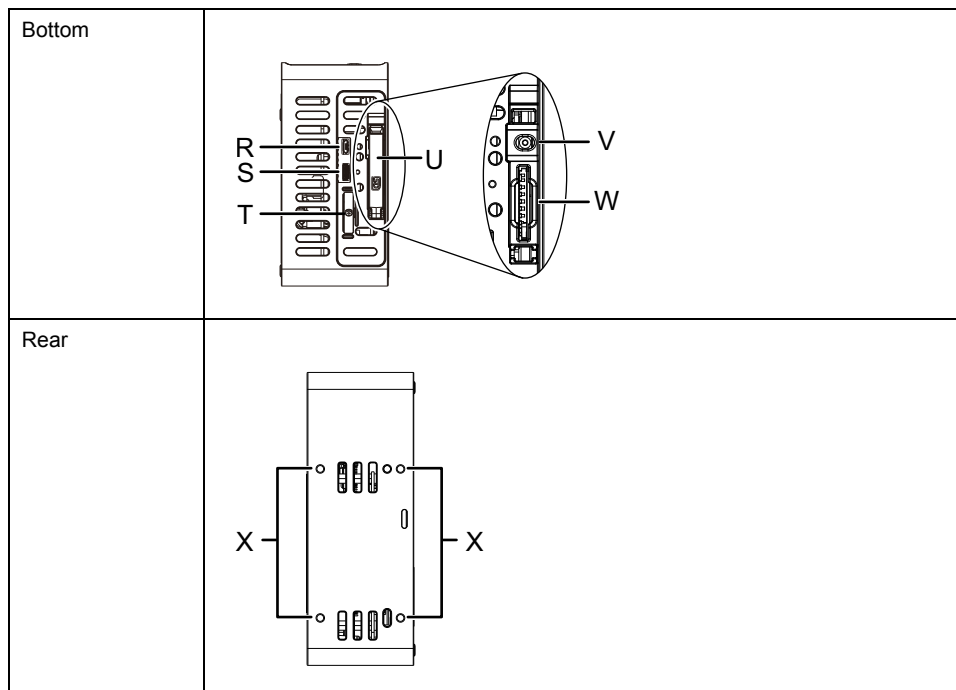

- | | |
|--|--|
| A. Power connector | N. SD card access LED (SD) |
| B. USB storage eject button* ¹ | O. Expansion unit interface* ⁴ |
| C. USB (Type-A) interface (x 2) | P. Safety alert symbol* ⁵ |
| D. Ethernet interface (ETH1) | Q. Safety alert symbol* ⁶ |
| E. Ethernet interface (ETH2)* ² | R. USB (micro-B) interface |
| F. Serial interface (COM1) | S. USB (Type-C) interface* ⁷ |
| G. Serial interface (COM2) | T. Battery slot cover |
| H. Security seal* ³ | U. SD card slot cover |
| I. Status LED (STA) | V. SD card eject button* ¹ |
| J. Error LED (ERR) | W. SD card slot |
| K. COM1 LED (COM1) | X. Screw holes for attaching the DIN rail attachment |
| L. COM2 LED (COM2) | Y. PE terminal (used for AC model only) |
| M. USB storage LED (USB) | Z. Safety alert symbol (AC model only)* ⁸ |

*¹ For details, refer to Eject Button, page 53.

*² The factory default for the ETH2 port is disabled. Use the **System Settings** to change it. For details, refer to GP6000 Series System Settings User Guide.

*³ For details, refer to Security Seal, page 13.

*⁴ There is an Expansion unit interface connector under the label. Remove the label only when installing the expansion unit to the product. For instructions on installing the expansion unit, refer to Expansion Unit Hardware Guide.

*⁵ Identifies the safety messages about the USB (micro-B) interface in Cable Connections, page 48.

*⁶ Identifies the safety messages about the battery in Replacing the Battery, page 97.

*⁷ The USB (Type-C) interface supports DisplayPort Alternate Mode.

*⁸ Identifies the safety messages about the power wiring in Wiring the Power Supply, page 74.

LED Indications (DIN Mount Type)

Status LED

After the power is turned on, the normal status indication by the LED is: red light > blinking orange > green light.

Color	Indicator	HMI operation
Green	ON	In operation/Offline
	Blinking (ON/OFF every 3 seconds)	Backlight OFF (Standby Mode)*1
Orange	Blinking	Software starting up
Red	ON	Power is ON.
-	OFF	Power is OFF.

*1 Only when an expansion display is connected to the USB (Type-C) interface.

For other LED indications, refer to the manual of your screen editing software.

Error LED

Color	Indicator	Description
Red	ON	Major error is detected.
	Blinking	Minor error is detected.
-	OFF	Normal operation

COM1/COM2 LED

Color	Indicator	Description
Yellow	ON	Data transmission in progress
-	OFF	No data transmission

USB Storage LED

Color	Indicator	Description
Green (Active)	ON	The USB Storage device is inserted.
-	OFF	The USB Storage device is not inserted. Or is not being accessed.

SD Card Access LED

Color	Indicator	Description
Green (Active)	ON	The SD card is inserted.
-	OFF	The SD card is not inserted. Or is not being accessed.

Ethernet LED

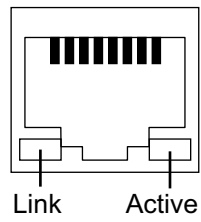

Color	Indicator	Description
Green (Link)	ON	Data transmission is available.
	OFF	No connection or error
Green (Active)	Blinking	Data transmission in progress
	ON	No data transmission
	OFF	No connection or error

Specifications

What's in This Chapter

General Specifications (Panel Mount Type)	36
General Specifications (DIN Mount Type)	42
Functional Specifications	45
Interface Specifications	46

General Specifications (Panel Mount Type)

Electrical Specifications (Panel Mount Type)

10, 12, 15-inch (AC Model)

		10-inch, AC model	12-inch, AC model	15-inch, AC model
Rated input voltage		100...240 Vac		
Input voltage limits		85...264 Vac		
Rated frequency		50/60 Hz		
Rated frequency range		47...63 Hz		
Voltage dip/short interruption immunity		20 ms or less (at rated input voltage)		
Power consumption	When power is supplied to expansion units	52 VA	55 VA	57 VA
	When power is not supplied to expansion units	37 VA	39 VA	42 VA
	When power is not supplied to external devices	34 VA	35 VA	36 VA
	When screen turns off the backlight (standby mode)	31 VA	31 VA	31 VA
In-rush current		30 A or less		
Noise immunity		Noise voltage: 1,500 Vp-p, Pulse duration: 1 μ s, Rise time: 1 ns (via noise simulator)		
Dielectric strength		1,500 Vac for 1 minute (between power terminal and PE terminal)		
Insulation resistance		500 Vdc, 10 M Ω or more (between power terminal and PE terminal)		

10, 12, 15-inch (DC Model)

		10-inch, DC model	12-inch, DC model	15-inch, DC model
Rated input voltage		12...24 Vdc		
Input voltage limits		10.8...28.8 Vdc		
Voltage dip/short interruption immunity		12 Vdc: 1.25 ms or less 24 Vdc: 5 ms or less		

		10-inch, DC model	12-inch, DC model	15-inch, DC model
Power consumption	When power is supplied to expansion units	41 W	45 W	48 W
	When power is not supplied to expansion units	23 W	26 W	29 W
	When power is not supplied to external devices	16 W	20 W	22 W
	When screen turns off the backlight (standby mode)	13 W	13 W	14 W
In-rush current		30 A or less		
Noise immunity		Noise voltage: 1,000 Vp-p, Pulse duration: 1 μ s, Rise time: 1 ns (via noise simulator)		
Dielectric strength		1,000 Vac for 1 minute (between power terminal and FG terminal)		
Insulation resistance		500 Vdc, 10 M Ω or more (between power terminal and FG terminal)		

10, 12, 15, 19, 22-inch Wide (AC Model)

		10-inch wide, AC model	12-inch wide, AC model
Rated input voltage		100...240 Vac	
Input voltage limits		85...264 Vac	
Rated frequency		50/60 Hz	
Rated frequency range		47...63 Hz	
Voltage dip/short interruption immunity		20 ms or less (at rated input voltage)	
Power consumption	When power is supplied to expansion units	52 VA	57 VA
	When power is not supplied to expansion units	37 VA	42 VA
	When power is not supplied to external devices	35 VA	36 VA
	When screen turns off the backlight (standby mode)	31 VA	31 VA
In-rush current		30 A or less	
Noise immunity		Noise voltage: 1,500 Vp-p, Pulse duration: 1 μ s, Rise time: 1 ns (via noise simulator)	
Dielectric strength		1,500 Vac for 1 minute (between power terminal and PE terminal)	
Insulation resistance		500 Vdc, 10 M Ω or more (between power terminal and PE terminal)	

		15-inch wide, AC model	19-inch wide, AC model	22-inch wide, AC model
Rated input voltage		100...240 Vac		
Input voltage limits		85...264 Vac		
Rated frequency		50/60 Hz		
Rated frequency range		47...63 Hz		
Voltage dip/short interruption immunity		20 ms or less (at rated input voltage)		
Power consumption	When power is supplied to expansion units	61 VA	66 VA	69 VA
	When power is not supplied to expansion units	46 VA	49 VA	52 VA
	When power is not supplied to external devices	39 VA	45 VA	47 VA
	When screen turns off the backlight (standby mode)	32 VA	33 VA	37 VA
In-rush current		30 A or less		
Noise immunity		Noise voltage: 1,500 Vp-p, Pulse duration: 1 μ s, Rise time: 1 ns (via noise simulator)		
Dielectric strength		1,500 Vac for 1 minute (between power terminal and PE terminal)		
Insulation resistance		500 Vdc, 10 M Ω or more (between power terminal and PE terminal)		

10, 12, 15, 19, 22-inch Wide (DC Model)

		10-inch wide, DC model	12-inch wide, DC model
Rated input voltage		12...24 Vdc	
Input voltage limits		10.8...28.8 Vdc	
Voltage dip/short interruption immunity		12 Vdc: 1.25 ms or less 24 Vdc: 5 ms or less	
Power consumption	When power is supplied to expansion units	42 W	47 W
	When power is not supplied to expansion units	23 W	28 W
	When power is not supplied to external devices	16 W	21 W
	When screen turns off the backlight (standby mode)	13 W	14 W
In-rush current		30 A or less	

	10-inch wide, DC model	12-inch wide, DC model
Noise immunity	Noise voltage: 1,000 Vp-p, Pulse duration: 1 µs, Rise time: 1 ns (via noise simulator)	
Dielectric strength	1,000 Vac for 1 minute (between power terminal and FG terminal)	
Insulation resistance	500 Vdc, 10 MΩ or more (between power terminal and FG terminal)	

	15-inch wide, DC model	19-inch wide, DC model	22-inch wide, DC model	
Rated input voltage	12...24 Vdc			
Input voltage limits	10.8...28.8 Vdc			
Voltage dip/short interruption immunity	12 Vdc: 1.25 ms or less 24 Vdc: 5 ms or less			
Power consumption	When power is supplied to expansion units	50 W	60 W	61 W
	When power is not supplied to expansion units	31 W	39 W	41 W
	When power is not supplied to external devices	24 W	32 W	33 W
	When screen turns off the backlight (standby mode)	14 W	16 W	17 W
In-rush current	30 A or less			
Noise immunity	Noise voltage: 1,000 Vp-p, Pulse duration: 1 µs, Rise time: 1 ns (via noise simulator)			
Dielectric strength	1,000 Vac for 1 minute (between power terminal and FG terminal)			
Insulation resistance	500 Vdc, 10 MΩ or more (between power terminal and FG terminal)			

Environmental Specifications (Panel Mount Type)

Use and store this product in areas that conform to the specified conditions.

NOTE: When using any of the options for this product, check the specifications for special conditions or cautions that may apply to this product.

Physical environment	
Ambient air temperature ¹	<ul style="list-style-type: none"> 10", 12", 15", 10" wide, 12" wide, 15" wide 0...60 °C (32...140 °F) 19" wide, 22" wide 0...50 °C (32...122 °F) Temperature class (T-Code): T4
Storage temperature	-20...60 °C (-4...140 °F)
Ambient air and storage humidity	10...90% RH (Non condensing, wet bulb temperature 39 °C [102.2 °F] or less)
Dust	0.1 mg/m ³ (10 ⁻⁷ oz/ft ³) or less (non-conductive levels)
Pollution degree	For use in Pollution Degree 2 environment
Corrosive gases	Free of corrosive gases

Atmospheric pressure (operating altitude)	800...1,114 hPa (2,000 m [6,561 ft] or lower)
Mechanical environment	
Vibration resistance	IEC/EN 61131-2 compliant 5...9 Hz Single amplitude 3.5 mm (0.14 in) 9...150 Hz Fixed acceleration: 9.8 m/s ² X, Y, Z directions for 10 cycles (approximately 100 minutes)
Shock resistance	IEC/EN 61131-2 compliant 147 m/s ² , X, Y, Z directions for 3 times
Electrical environment	
Electrical fast transient/burst immunity	IEC 61000-4-4 2 kV: Power port 1 kV: Signal ports
Electrostatic discharge immunity	Contact discharge method: 6 kV Air discharge method: 8 kV (IEC/EN 61000-4-2 Level 3)

*1 When the ambient air temperature is from 0 to 40 °C (32 to 104 °F), the product is classified as temperature class T6.

▲ CAUTION
INOPERATIVE EQUIPMENT
<ul style="list-style-type: none"> Do not operate or store the product where chemicals evaporate, or where chemicals are present in the air. Chemicals refer to the following: A) Corrosive chemicals: Acids, alkalines, liquids containing salt, B) Flammable chemicals: Organic solvents. Do not allow water, liquids, metal, and wiring fragments to enter the panel case. <p>Failure to follow these instructions can result in injury or equipment damage.</p>

Structural Specifications (Panel Mount Type)

10, 12, 15-inch Model

	10-inch	12-inch	15-inch
Grounding	DC model: Functional grounding: Grounding resistance of 100 Ω or less, 2 mm ² (14 AWG) or thicker wire, or your country's applicable standard (SG and FG are connected inside the product). AC model: Protective grounding: Grounding resistance of 100 Ω or less, 2 mm ² (14 AWG) or thicker wire, or your country's applicable standard (SG and PE are connected inside the product).		
Cooling method	Natural air circulation		
Structure*1	<ul style="list-style-type: none"> Front When using a factory-installed front USB cover: IP65F, IP67F, UL 50/50E, Type 1 When using a front USB cover with screw (PFXZCDCVUS1): IP66F, IP67F, UL 50/50E, Type 1, Type 4X (indoor use only), Type 12, Type 13 NOTE: On the front panel when properly installed in an enclosure and not using the front panel USB port. Rear IP20 		
External dimensions (W x H x D)	272.5 x 214.5 x 64 mm (10.73 x 8.44 x 2.52 in)	315 x 241 x 64 mm (12.4 x 9.49 x 2.52 in)	397 x 296 x 64 mm (15.63 x 11.65 x 2.52 in)

	10-inch	12-inch	15-inch
Panel cutout dimensions (W x H) ^{2*3}	259 x 201 mm (10.2 x 7.91 in) Panel thickness range: 1.6...5 mm (0.06...0.2 in)	301.5 x 227.5 mm (11.87 x 8.96 in) Panel thickness range: 1.6...5 mm (0.06...0.2 in)	383.5 x 282.5 mm (15.1 x 11.12 in) Panel thickness range: 1.6...5 mm (0.06...0.2 in)
Weight	3.1 kg (6.83 lb) or less	3.7 kg (8.16 lb) or less	5 kg (11.02 lb) or less

10, 12, 15, 19, 22-inch Wide Model

	10-inch wide	12-inch wide
Grounding	DC model: Functional grounding: Grounding resistance of 100 Ω or less, 2 mm ² (14 AWG) or thicker wire, or your country's applicable standard (SG and FG are connected inside the product). AC model: Protective grounding: Grounding resistance of 100 Ω or less, 2 mm ² (14 AWG) or thicker wire, or your country's applicable standard (SG and PE are connected inside the product).	
Cooling method	Natural air circulation	
Structure ^{*1}	<ul style="list-style-type: none"> • Front IP66F, IP67F, UL 50/50E, Type 1, Type 4X (indoor use only), Type 12, Type 13 • Rear IP20 	
External dimensions (W x H x D)	268.5 x 198.5 x 64 mm (10.57 x 7.81 x 2.52 in)	308.5 x 230.5 x 64 mm (12.15 x 9.07 x 2.52 in)
Panel cutout dimensions (W x H) ^{2*3}	255 x 185 mm (10.04 x 7.28 in) Panel thickness range: 1.6...3 mm (0.06...0.12 in)	295 x 217 mm (11.61 x 8.54 in) Panel thickness range: 1.6...5 mm (0.06...0.2 in)
Weight	3.2 kg (7.05 lb) or less	3.85 kg (8.49 lb) or less

	15-inch wide	19-inch wide	22-inch wide
Grounding	DC model: Functional grounding: Grounding resistance of 100 Ω or less, 2 mm ² (14 AWG) or thicker wire, or your country's applicable standard (SG and FG are connected inside the product). AC model: Protective grounding: Grounding resistance of 100 Ω or less, 2 mm ² (14 AWG) or thicker wire, or your country's applicable standard (SG and PE are connected inside the product).		
Cooling method	Natural air circulation		
Structure ^{*1}	<ul style="list-style-type: none"> • Front IP66F, IP67F, UL 50/50E, Type 1, Type 4X (indoor use only), Type 12, Type 13 • Rear IP20 		
External dimensions (W x H x D)	408 x 264 x 64 mm (16.06 x 10.39 x 2.52 in)	463.6 x 293.6 x 66 mm (18.25 x 11.56 x 2.6 in)	532.6 x 330.6 x 66 mm (20.97 x 13.02 x 2.6 in)
Panel cutout dimensions (W x H) ^{2*3}	394 x 250 mm (15.51 x 9.84 in) Panel thickness range: 1.6...5 mm (0.06...0.2 in)	449.5 x 279.5 mm (17.7 x 11.0 in) Panel thickness range: 1.6...5 mm (0.06...0.2 in)	518.5 x 316.5 mm (20.41 x 12.46 in) Panel thickness range: 1.6...5 mm (0.06...0.2 in)
Weight	5.3 kg (11.68 lb) or less	6.4 kg (14.1 lb) or less	7.5 kg (16.53 lb) or less

*1 The front of this product has been tested to comply with the specified standards when installed in a solid panel. However, it is not intended for use in all environments. In environments where the product is exposed to liquids (including jets and sprays) for extended periods, there is a risk that liquids may enter the product due to causes such as peeling of the protective sheet or damage to the

front glass cover. In such environments, implement appropriate protective measures based on the specific conditions. Therefore, prior to installing this product, be sure to confirm the type of conditions that will be present in this product's operating environment.

If the installation gasket is used for a long period of time, or if this product and its gasket are removed from the panel, the original level of protection cannot be kept. To maintain the original protection level, be sure to replace the installation gasket regularly.

*2 The dimensional tolerance for the width and height of the panel cutout is +1/-0 mm (+0.04/-0 in). All the corners have a radius of R3 mm (R0.12 in) or less.

*3 Even if the installation wall thickness is within the specified range, depending on the wall's material, size, and installation location of this product and other devices, the installation wall could warp. To prevent warping, the installation surface may need to be strengthened.

NOTE: IP65F, IP66F and IP67F are not part of UL certification.

NOTICE

EQUIPMENT DAMAGE

- Ensure this product is not in permanent and direct contact with oils.
- Do not press on the display of this product with excessive force or with a hard object.
- Do not press on the touch panel with a pointed object, such as the tip of a mechanical pencil or a screwdriver.
- Do not expose the product to direct sunlight.
- Operate and store this product in areas where temperatures are within the product's specifications.
- Do not restrict or block the product's ventilation slots.

Failure to follow these instructions can result in equipment damage.

NOTICE

EQUIPMENT DAMAGE

- Inspect the gasket periodically as required by your operating environment.
- Replace the gasket at least once a year, or as soon as scratches or dirt become visible.

Failure to follow these instructions can result in equipment damage.

General Specifications (DIN Mount Type)

Electrical Specifications (DIN Mount Type)

AC Model

Rated input voltage	100...240 Vac
Input voltage limits	85...264 Vac
Rated Frequency	50/60 Hz
Rated Frequency Range	47...63 Hz
Voltage dip/short interruption immunity	20 ms or less (at rated input voltage)

Power consumption	When power is supplied to expansion units and expansion display*1	75 VA
	When power is not supplied to expansion units and expansion display	37 VA
	When power is not supplied to external devices	29 VA
In-rush current		30 A or less
Noise immunity		Noise voltage: 1,500 Vp-p, Pulse duration: 1 μ s, Rise time: 1 ns (via noise simulator)
Dielectric strength		1,500 Vac for 1 minute (between power terminal and PE terminal)
Insulation resistance		500 Vdc, 10 M Ω or more (between power terminal and PE terminal)

*1 Power consumption when devices are connected to the expansion unit interface and the USB (Type-C) interface.

DC Model

Rated input voltage		12...24 Vdc
Input voltage limits		10.8...28.8 Vdc
Voltage dip/short interruption immunity		12 Vdc: 1.25 ms or less 24 Vdc: 5 ms or less
Power consumption	When power is supplied to expansion units and expansion display*1	70 W
	When power is not supplied to expansion units and expansion display	20 W
	When power is not supplied to external devices	12 W
In-rush current		30 A or less
Noise immunity		Noise voltage: 1,000 Vp-p, Pulse duration: 1 μ s, Rise time: 1 ns (via noise simulator)
Dielectric strength		1,000 Vac for 1 minute (between power terminal and FG terminal)
Insulation resistance		500 Vdc, 10 M Ω or more (between power terminal and FG terminal)

*1 Power consumption when devices are connected to the expansion unit interface and the USB (Type-C) interface.

Environmental Specifications (DIN Mount Type)

Use and store this product in areas that conform to the specified conditions.

NOTE: When using any of the options for this product, check the specifications for special conditions or cautions that may apply to this product.

Physical environment	
Ambient air temperature*1	-20...60 °C (-4...140 °F) Temperature class (T-Code): T4
Storage temperature	-20...60 °C (-4...140 °F)
Ambient air and storage humidity	10...90% RH (Non condensing, wet bulb temperature 39 °C [102.2 °F] or less)

Dust	0.1 mg/m ³ (10 ⁻⁷ oz/ft ³) or less (non-conductive levels)
Pollution degree	For use in Pollution Degree 2 environment
Corrosive gases	Free of corrosive gases
Atmospheric pressure (operating altitude)	800...1,114 hPa (2,000 m [6,561 ft] or lower)
Mechanical environment	
Vibration resistance	IEC/EN 61131-2 compliant 5...9 Hz Single amplitude 3.5 mm (0.14 in) 9...150 Hz Fixed acceleration: 9.8 m/s ² X, Y, Z directions for 10 cycles (approximately 100 minutes)
Shock resistance	IEC/EN 61131-2 compliant 147 m/s ² , X, Y, Z directions for 3 times
Electrical environment	
Electrical fast transient/burst immunity	IEC 61000-4-4 2 kV: Power port 1 kV: Signal ports
Electrostatic discharge immunity	Contact discharge method: 6 kV Air discharge method: 8 kV (IEC/EN 61000-4-2 Level 3)

*1 When the ambient air temperature is from -20 to 40 °C (-4 to 104 °F), the product is classified as temperature class T6.

▲ CAUTION

INOPERATIVE EQUIPMENT

- Do not operate or store the product where chemicals evaporate, or where chemicals are present in the air. Chemicals refer to the following: A) Corrosive chemicals: Acids, alkalines, liquids containing salt, B) Flammable chemicals: Organic solvents.
- Do not allow water, liquids, metal, and wiring fragments to enter the panel case.

Failure to follow these instructions can result in injury or equipment damage.

Structural Specifications (DIN Mount Type)

Grounding	DC model: Functional grounding: Grounding resistance of 100 Ω or less, 2 mm ² (14 AWG) or thicker wire, or your country's applicable standard (SG and FG are connected inside the product). AC model: Protective grounding: Grounding resistance of 100 Ω or less, 2 mm ² (14 AWG) or thicker wire, or your country's applicable standard (SG and PE are connected inside the product).
Cooling method	Natural air circulation
Structure	IP20
External dimensions (W x H x D)	173 x 131.7 x 63 mm (6.81 x 5.19 x 2.48 in)
Weight	1.4 kg (3.08 lb) or less

Functional Specifications

Display Specifications

10, 12, 15-inch Model

	10-inch	12-inch	15-inch
Display type	TFT Color LCD		
Display size	10.4"	12.1"	15"
Resolution	800 x 600 pixels (SVGA)	1,024 x 768 pixels (XGA)	
Effective display area (W x H)	211.2 x 158.4 mm (8.31 x 6.24 in)	245.76 x 184.32 mm (9.68 x 7.26 in)	304.13 x 228.1 mm (11.97 x 8.98 in)
Display colors	16 million colors For details about display colors, refer to the manual of your screen editing software.		
Backlight	White LED (Not replaceable.)		
Backlight service life	50,000 hours or more (continuous operation at 25 °C [77 °F] before backlight brightness decreases to 50%)		
Brightness control	0...100 (adjusted with touch panel or software)		

10, 12, 15, 19, 22-inch Wide Model

	10-inch wide	12-inch wide
Display type	TFT Color LCD	
Display size	10.1" wide	12.1" wide
Resolution	1,280 x 800 pixels (WXGA)	
Effective display area (W x H)	216.96 x 135.6 mm (8.54 x 5.34 in)	261.12 x 163.2 mm (10.28 x 6.43 in)
Display colors	16 million colors For details about display colors, refer to the manual of your screen editing software.	
Backlight	White LED (Not replaceable.)	
Backlight service life	50,000 hours or more (continuous operation at 25 °C [77 °F] before backlight brightness decreases to 50%)	
Brightness control	0...100 (adjusted with touch panel or software)	

	15-inch wide	19-inch wide	22-inch wide
Display type	TFT Color LCD		
Display size	15.6" wide	18.5" wide	21.5" wide
Resolution	1,920 x 1,080 pixels (FHD)		
Effective display area (W x H)	344.16 x 193.59 mm (13.55 x 7.62 in)	408.96 x 230.04 mm (16.1 x 9.06 in)	476.64 x 268.11 mm (18.77 x 10.56 in)
Display colors	16 million colors For details about display colors, refer to the manual of your screen editing software.		
Backlight	White LED (Not replaceable.)		
Backlight service life	50,000 hours or more (continuous operation at 25 °C [77 °F] before backlight brightness decreases to 50%)		
Brightness control	0...100 (adjusted with touch panel or software)		

Touch Panel

	10-inch, 12-inch, 15-inch	10-inch wide, 12-inch wide, 15-inch wide, 19-inch wide, 22-inch wide
Touch panel type	Resistive film (analog)	Projected capacitive (PCAP) with optimized noise filter
Touch points	Multi-touch (two-point touch)	Multi-touch (two-point touch)
Touch panel service life	1 million times or more	50 million times or more
Touch panel resolution	1,024 x 1,024	2,048 x 2,048
Touch mode	Not applicable	Standard mode, Water detection mode, Glove mode NOTE: Change the mode in the System Settings .

Memory

System memory*1	eMMC Flash 4 GB (operating system, project data and other data)
Backup memory*1	NVRAM 512 KB

*1 For the usage capacity of each memory, refer to the following URL.
<https://www.pro-face.com/trans/en/manual/1082.html>

Clock

RTC accuracy	Deviation of ± 65 seconds per month (at 25 °C [77 °F] and power is OFF).
Clock data backup	Lithium metal battery (non-rechargeable battery, replaceable) Battery life: 5 years (approximate)

Variations in operating conditions and battery life can cause clock deviations from -380 to +90 seconds per month. If you use this product in a system where timing is critical, adjust the clock at regular intervals.

If the battery is depleted or removed, the clock data will be lost. To replace the battery, refer to *Replacing the Battery*, page 97.

Interface Specifications

Specifications of Each Interface

Use only the SELV (Safety Extra-Low Voltage) circuit to connect the interfaces.

	10-inch, 12-inch, 15-inch	10-inch wide, 12-inch wide, 15-inch wide, 19-inch wide, 22-inch wide, DIN mount type
Serial interface (COM1)		
Connector	D-Sub 9 pin (plug)	
Asynchronous transmission	RS-232C	
Data length	7 or 8 bits	

	10-inch, 12-inch, 15-inch	10-inch wide, 12-inch wide, 15-inch wide, 19-inch wide, 22-inch wide, DIN mount type
Stop bit	1 or 2 bits	
Parity	None, odd, or even	
Data transmission speed	2,400...115,200 bps	
Serial interface (COM2)		
Connector	D-Sub 9 pin (plug)	
Asynchronous transmission	RS-422/485	
Data length	7 or 8 bits	
Stop bit	1 or 2 bits	
Parity	None, odd, or even	
Data transmission speed	2,400...115,200 bps, 187,500 bps (MPI)	
USB (Type-A) interface		
Connector	USB 2.0 (Type-A) x 3 ^{*1}	USB 2.0 (Type-A) x 2
Power supply voltage	5 Vdc ±5%	
Maximum current supplied	500 mA/port ^{*2}	
Maximum transmission distance	5 m (16.4 ft)	
USB (micro-B) interface		
Connector	USB 2.0 (micro-B) x 2 ^{*1}	USB 2.0 (micro-B) x 1
Maximum transmission distance	5 m (16.4 ft)	
USB (Type-C) interface^{*3}		
Connector	-	USB 2.0 (Type-C) x 1
Power supply voltage	-	5 Vdc ±5% or 12 Vdc ±5%, USB power delivery (source) supported
Maximum current supplied	-	When power supply voltage is 5 Vdc ±5%: 1 A When power supply voltage is 12 Vdc ±5%: 2.5 A
Maximum transmission distance	-	5 m (16.4 ft)
Ethernet interface		
Connector	Modular jack (RJ-45) x 2 ^{*4}	
Standard	IEEE802.3i/IEEE802.3u, 10BASE-T/100BASE-TX/1000BASE-T ^{*5}	
SD card interface		
Connector	SD card slot x 1	
Standard	SD/SDHC/SDXC, UHS-I supported	

*1 The factory default for the Front USB ports (Type-A and micro-B) is disabled. For instructions on enabling the USB ports, refer to GP6000 Series System Settings User Guide.

*2 For USB allowable current to provided is limited 1 A total.

*3 DIN mount type only. The USB (Type-C) interface supports DisplayPort Alternate Mode.

*4 The factory default for the ETH2 port is disabled. Use the **System Settings** to change it. For details, refer to GP6000 Series System Settings User Guide.

*5 For 1000BASE-T communication, use twisted pair Ethernet cables with a rating of category 5e or higher.

Interface Connection

Cable Connections

⚠ WARNING

EXPLOSION HAZARD

- Always confirm the UL 121201 or CSA C22.2 No.213 hazardous location rating of your device before installing or using it in a hazardous location.
- To apply or remove the supply power from this product installed in a Class I, Division 2 hazardous location, you must either: A) Use a switch located outside the hazardous environment, or B) Use a switch certified for Class I, Division 1 operation inside the hazardous area.
- Do not connect or disconnect equipment unless power has been switched off or the area is known to be non-hazardous. This applies to all connections including power, ground, serial, parallel, and network connections.
- Always use shielded/grounded cables in hazardous locations.
- Use only non-incendive USB devices.
- Use the USB (micro-B) interface for temporary connection only during maintenance and setup of the device.
- Do not use the USB (micro-B) interface in hazardous locations.

Failure to follow these instructions can result in death, serious injury, or equipment damage.

Division 2 hazardous location regulations require that all cable connections be provided with adequate strain relief and positive interlock. As this product does not provide adequate strain relief for the USB connection (USB micro-B interface) on this product, use only non-incendive USB devices. Never connect or disconnect a cable while power is applied at either end of the cable. All communication cables should include a chassis ground shield. This shield should include both copper braid and aluminum foil. The D-Sub style connector housing must be a metal conductive type (for example, molded zinc) and the ground shield braid must be terminated directly to the connector housing. Do not use a shield drain wire.

The outer diameter of the cable must be suited to the inner diameter of the cable connector strain relief so that a reliable degree of strain relief is maintained. Always secure the D-Sub connectors to the workstation-mating connectors via the two screws located on both sides.

USB Connection

Non-incendive field wiring apparatus (keyboards, mouse) are permitted for use on the front USB port (Type-A) of associated field wiring non-incendive apparatus (this product).

In addition to being non-incendive, any equipment connected to the front USB ports must satisfy the following criteria.

The following figure shows the USB cable wiring (Document No.: NNZ2083601)

<Type-A>

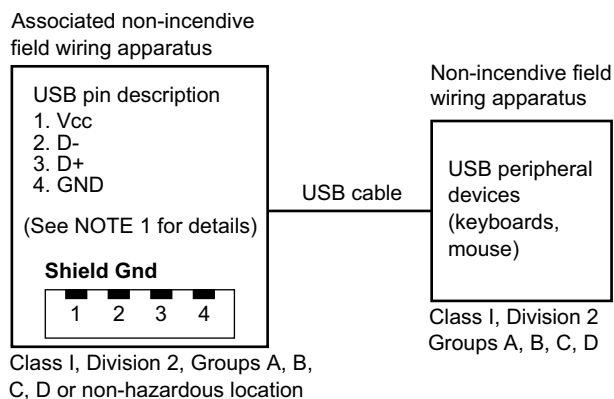

Circuit parameters	Front USB (Type-A)
Open-circuit voltage = V_{oc}	5.25 Vdc
Short-circuit current = I_{sc}	1,560 mA
Associated capacitance = C_a	265 μ F
Associated inductance = L_a	16 μ H

<micro-B>

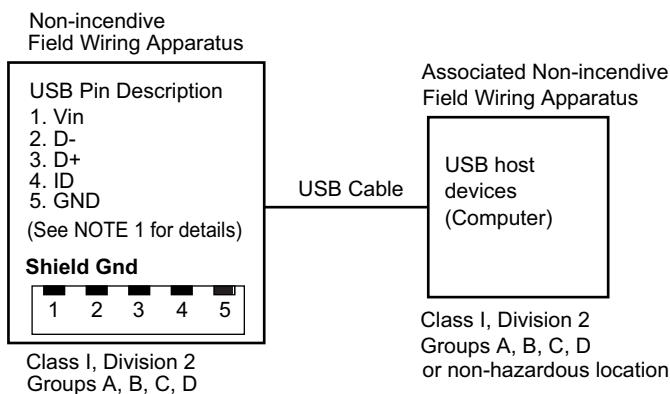

Circuit parameters	Front USB (micro-B)
Maximum input voltage = V_{max}	5.25 Vdc
Maximum load current = I_{max}	0.1 mA
Internal capacitance = C_i	0.12 μ F
Internal inductance = L_i	16 μ H

NOTE:

1. The above tables list the non-incendive circuit parameters.

The Entity Concept allows interconnection of non-incendive apparatus with associated apparatus – not specifically examined combinations – as a system when the approved values of V_{oc} (or U_o) and I_{sc} (or I_o) for the associated apparatus are less than or equal to V_{max} (U_i) and I_{max} (I_i) for the non-incendive apparatus, and the approved values of C_a (C_o) and L_a (L_o) for the associated apparatus are greater than or equal to $C_i + C_{cable}$ and $L_i + L_{cable}$, respectively, for the non-incendive field wiring apparatus.

2. Associated non-incendive field wiring apparatus and non-incendive field wiring apparatus shall satisfy the following:

Associated non-incendive field wiring apparatus	—	Non-incendive field wiring apparatus
V_{oc}	\leq	V_{max}
I_{sc}	\leq	I_{max}
C_a	\geq	$C_i + C_{cable}$
L_a	\geq	$L_i + L_{cable}$

3. If the electrical parameters of the cable are unknown, the following values may be used:

$$C_{cable} = 196.85 \text{ pF/m (60 pF/ft)}$$

$$L_{cable} = 0.656 \text{ }\mu\text{H/m (0.20 }\mu\text{H/ft)}$$

4. Wiring methods must be in accordance with the electrical code of the country where it is used.

This product must be installed in an enclosure. If installed in a Class I, Division 2 location, the enclosure must be capable of accepting one or more Division 2 wiring methods.

⚠ WARNING

EXPLOSION HAZARD

- Verify the power, input, and output (I/O) wiring are in accordance with Class I, Division 2 wiring methods.
- Do not use this product in hazardous environments or locations other than Class I, Division 2, Groups A, B, C, and D.
- Substitution of any components may impair suitability for Class I, Division 2.
- Do not disconnect equipment while the circuit is live or unless the area is known to be free of ignitable concentrations.
- Remove power before attaching or detaching any connectors to or from this product.
- Ensure that power, communication, and accessory connections do not place excessive stress on the ports. Consider the vibration in the environment when making this determination.
- Securely attach power, communication, and external accessory cables to the panel or cabinet.
- Use only commercially available USB cables.
- Use only non-incendive USB configurations.
- Confirm that the USB cable has been attached with the USB cable clamp before using the USB interface.

Failure to follow these instructions can result in death, serious injury, or equipment damage.

Serial Interface

Precautions for Connecting Serial Interface

The serial interface is not isolated. The SG (signal ground) and FG (frame ground) terminals are connected inside the product. When the serial interface connector is D-Sub, connect the FG wire to the shell.

NOTE: For information on how to connect controllers and other types of equipment, refer to the corresponding device driver manual of your screen editing software.

⚠️⚠️ DANGER

ELECTRIC SHOCK AND FIRE

- Verify that a ground loop is not created when you set up the system.
- When the SG and FG on the external device are not isolated, connect the product's SG to the SG on the external device.
- Connect the SG to a known reliable ground connection to reduce the risk of damaging the circuit.

Failure to follow these instructions will result in death or serious injury.

⚠️ CAUTION

LOSS OF COMMUNICATION

- Do not put excessive stress on the communication ports of all connections.
- Securely attach communication cables to the panel wall or cabinet.
- Use a D-Sub 9 pin connector that has jack screws.

Failure to follow these instructions can result in injury or equipment damage.

NOTE: Use within the rated current.

RS-232C (COM1)

D-Sub 9 pin plug connector

Product side:

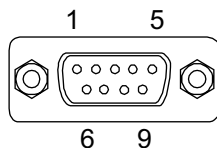

Pin No.	RS-232C		
	Signal name	Direction	Meaning
1	CD	Input	Carrier detect
2	RD (RXD)	Input	Receive data
3	SD (TXD)	Output	Send data
4	ER (DTR)	Output	Data terminal ready
5	SG	–	Signal ground
6	DR (DSR)	Input	Data set ready
7	RS (RTS)	Output	Request to send

Pin No.	RS-232C		
	Signal name	Direction	Meaning
8	CS (CTS)	Input	Send possible
9	CI (RI)/VCC	Input/-	+5 Vdc \pm 5% Output 0.25 A ^{*1}
Shell	FG	–	Frame ground (common with SG)

*1 When using RS-232C pin #9, enable CI (RI)/VCC with the software.

Recommended jack screw is #4-40 (UNC).

Recommendations:

- Cable Connector: XM3D-0921 manufactured by OMRON Corporation.
- Cable Cover: XM2S-0913 manufactured by OMRON Corporation.
- Jack Screw (#4-40 UNC): XM2Z-0073 manufactured by OMRON Corporation.

RS-422/485 (COM2)

D-Sub 9 pin plug connector

Product side:

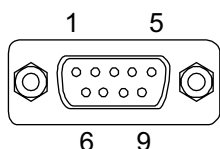

Pin No.	RS-422/RS-485		
	Signal name	Direction	Meaning
1	RDA	Input	Receive data A (+)
2	RDB	Input	Receive data B (-)
3	SDA	Output	Send data A (+)
4	ERA	Output	Data terminal ready A (+)
5	SG	–	Signal ground
6	CSB	Input	Send possible B (-)
7	SDB	Output	Send data B (-)
8	CSA	Input	Send possible A (+)
9	ERB	Output	Data terminal ready B (-)
Shell	FG	–	Frame ground (common with SG)

Recommended jack screw is #4-40 (UNC).

Recommendations:

- Cable Connector: XM3D-0921 manufactured by OMRON Corporation.
- Cable Cover: XM2S-0913 manufactured by OMRON Corporation.
- Jack Screw (#4-40 UNC): XM2Z-0073 manufactured by OMRON Corporation.

Eject Button

The DIN mount type has two eject buttons, one for the SD card and one for the USB storage.

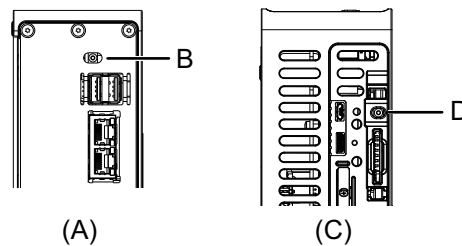

- A. Front side
- B. USB storage eject button
- C. Bottom side
- D. SD card eject button

Each eject button has two functions.

USB storage eject button

- Pressing the eject button once enables you to Safely Remove Hardware. After the USB storage is disconnected (unmounted), the USB storage LED turns off.
- If you power on the product while holding down the USB storage eject button, the product boots up with the default IP address and the **System Settings** is available for configuration. For more information, refer to GP6000 Series System Settings User Guide.

SD card eject button

- Pressing the eject button once will enable you to Safely Remove Hardware. When the SD card is disconnected (unmounted), the SD card access LED turns off. For SD card removal, refer to *Removing the SD Card*, page 86.
- If you press and hold the SD card eject button for more than four seconds, the product will reboot. When the status LED turns off and then lights up red, release the eject button.

Dimensions

What's in This Chapter

External Dimensions (10-inch Model).....	54
External Dimensions (12-inch Model).....	55
External Dimensions (15-inch Model).....	55
External Dimensions (10-inch Wide Model).....	56
External Dimensions (12-inch Wide Model).....	57
External Dimensions (15-inch Wide Model).....	57
External Dimensions (19-inch Wide Model).....	58
External Dimensions (22-inch Wide Model).....	59
Installation Fastener.....	59
External Dimensions (DIN Mount Type).....	60

External Dimensions (10-inch Model)

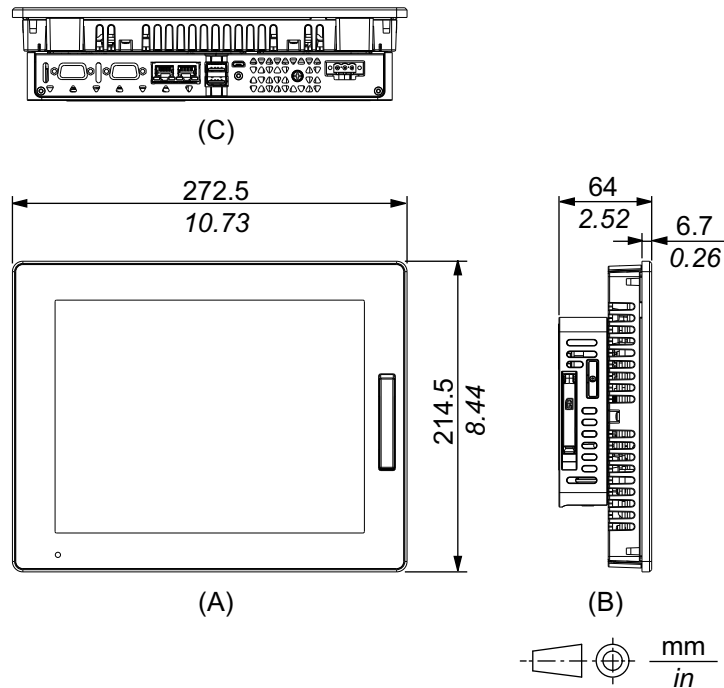

- A. Front
- B. Left
- C. Bottom

External Dimensions (12-inch Model)

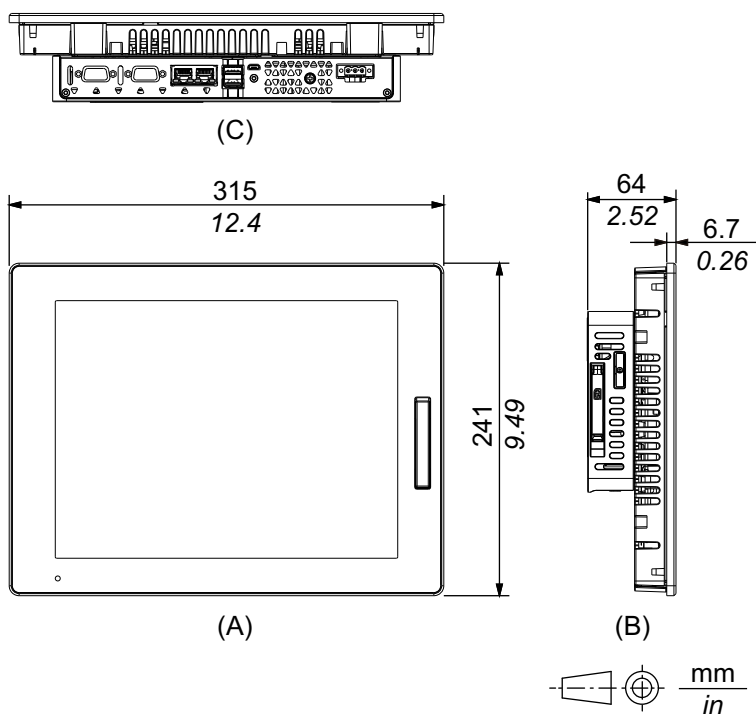

- A. Front
- B. Left
- C. Bottom

External Dimensions (15-inch Model)

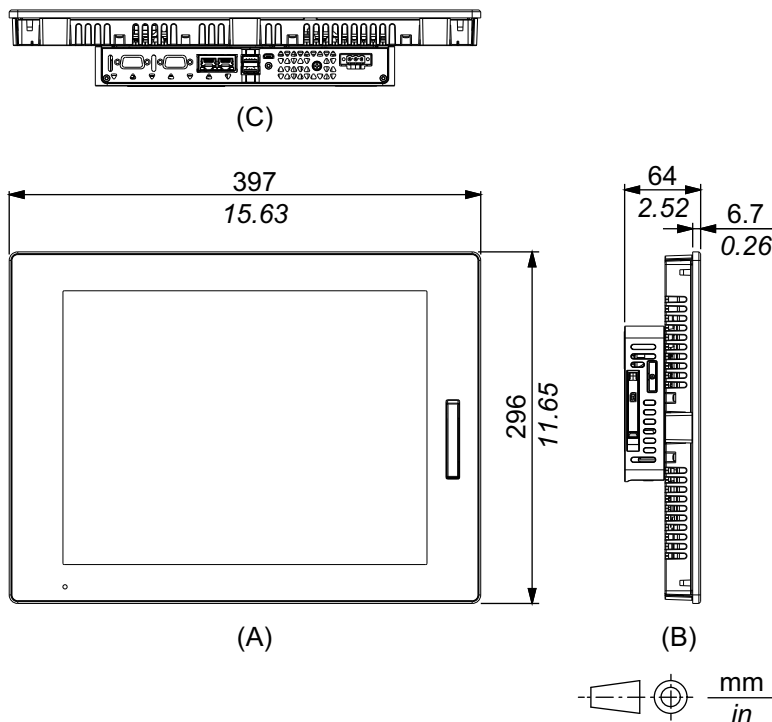

- A. Front
- B. Left
- C. Bottom

External Dimensions (10-inch Wide Model)

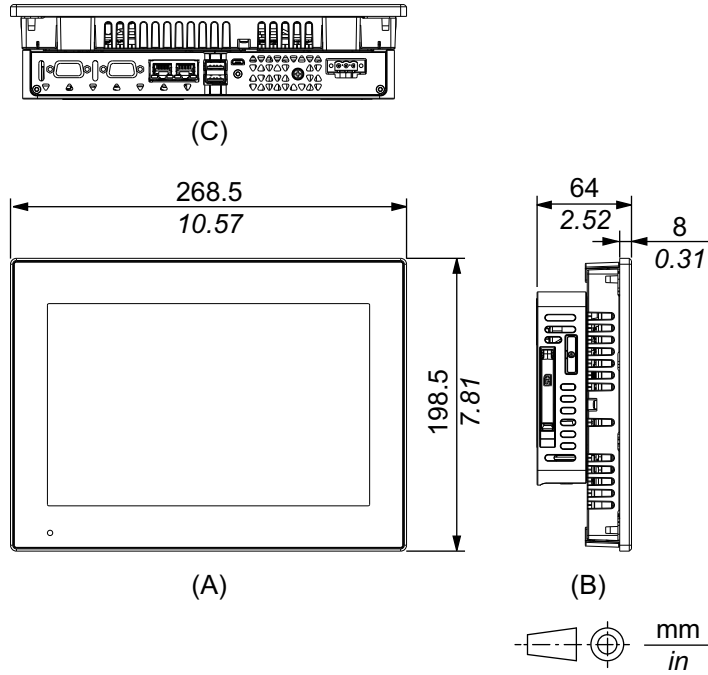

- A. Front
- B. Left
- C. Bottom

External Dimensions (12-inch Wide Model)

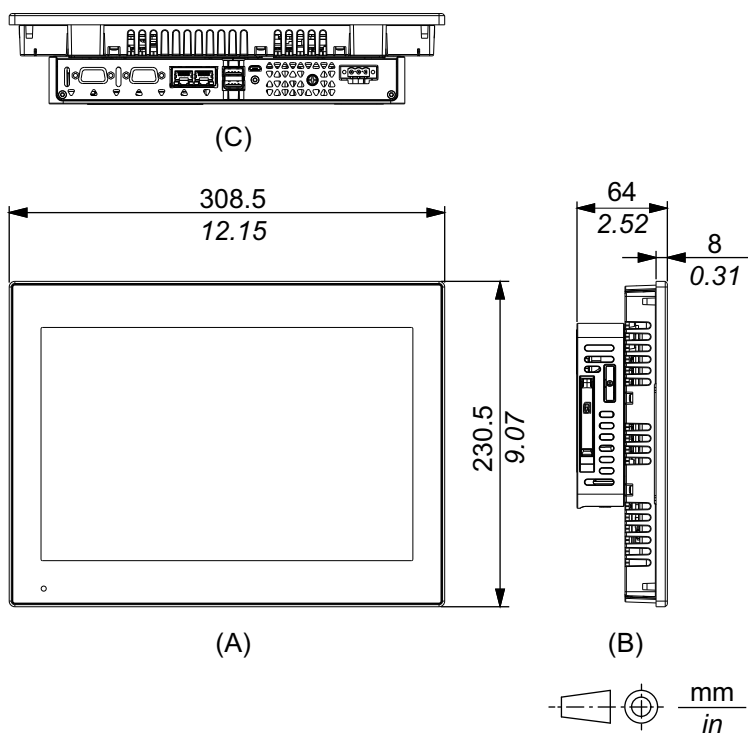

- A. Front
- B. Left
- C. Bottom

External Dimensions (15-inch Wide Model)

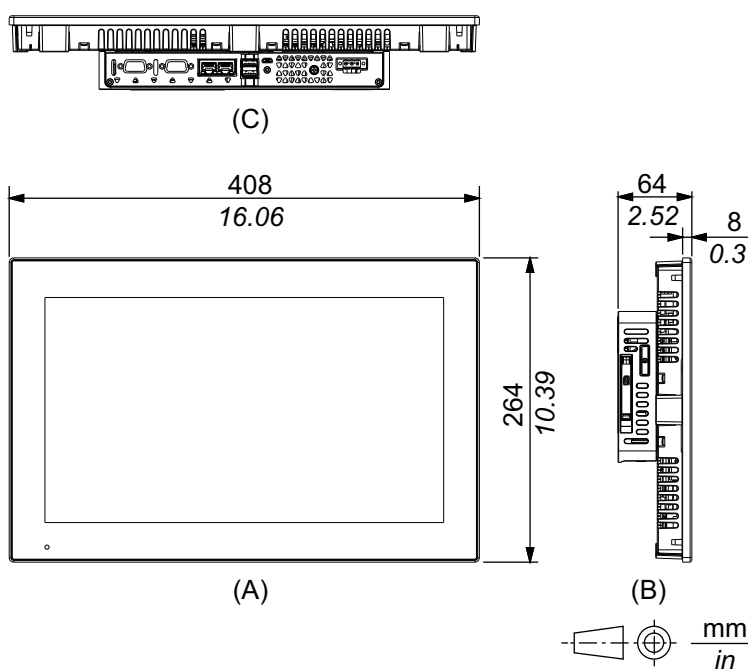

- A. Front

- B. Left
- C. Bottom

External Dimensions (19-inch Wide Model)

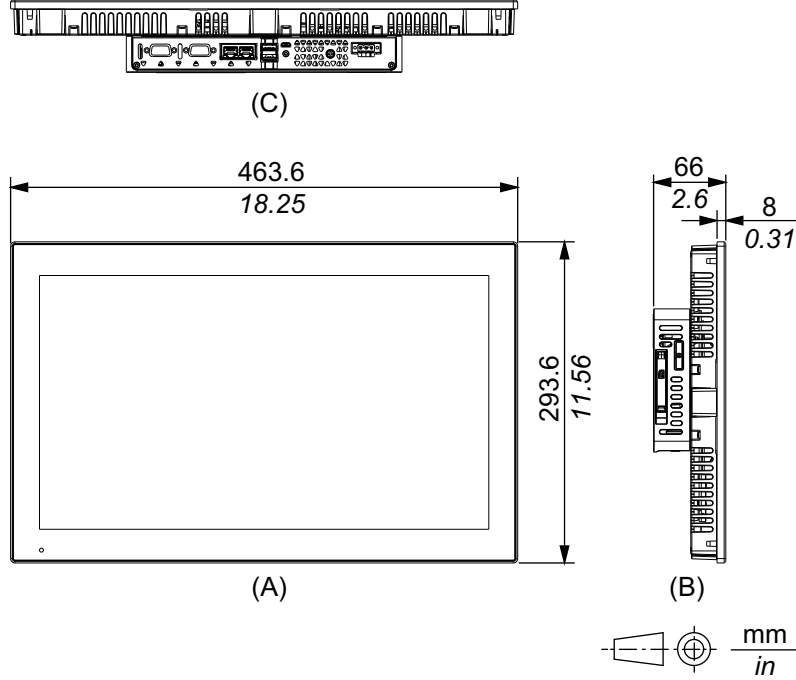

- A. Front
- B. Left
- C. Bottom

External Dimensions (22-inch Wide Model)

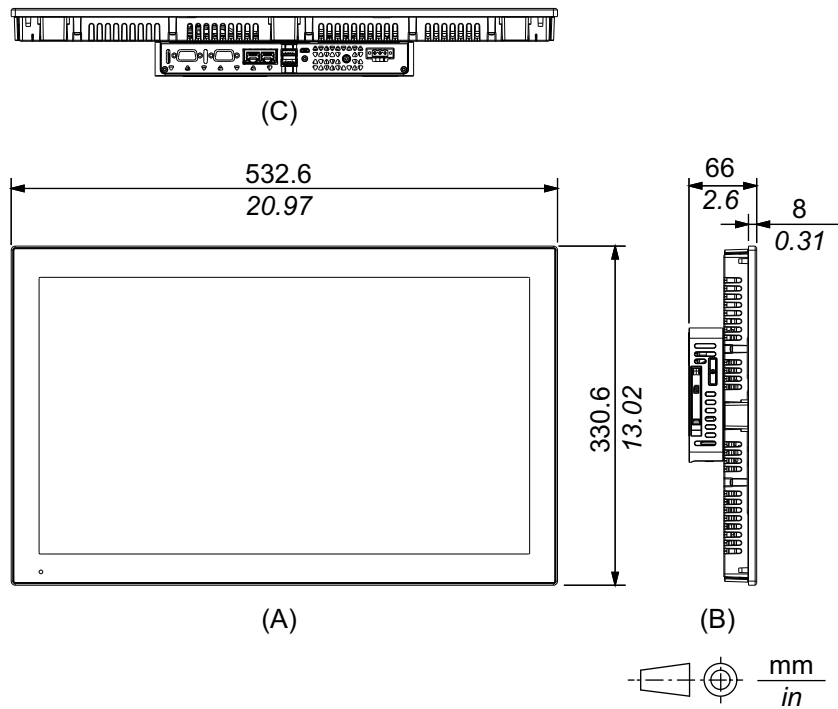

- A. Front
- B. Left
- C. Bottom

Installation Fastener

External Dimensions

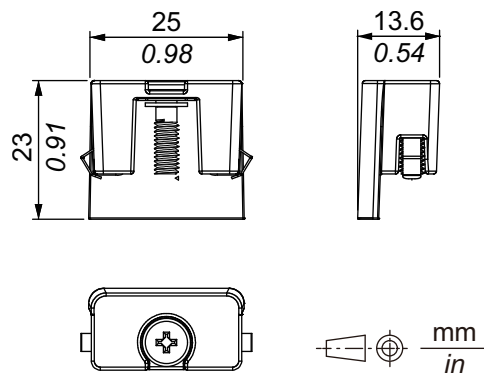

External Dimensions (DIN Mount Type)

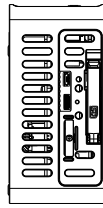

(C)

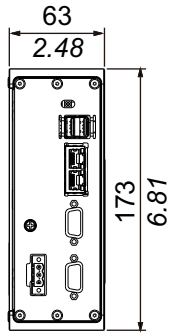

(A)

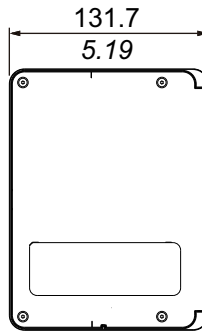

(B)



- A. Front
- B. Left
- C. Bottom

Dimensions with DIN Rail Attachment Installed

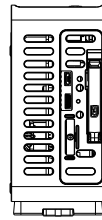

(E)

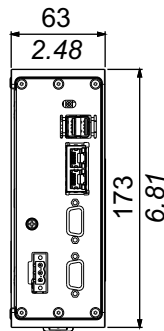

(A)

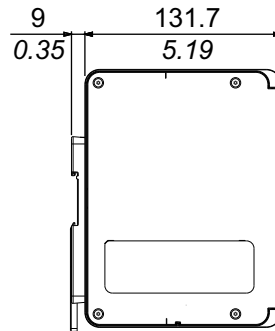

(B)

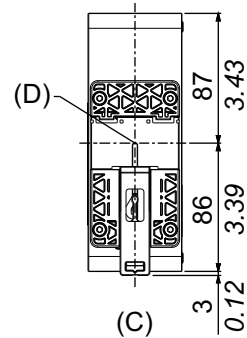

(C)

(D)

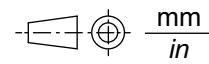

- A. Front
- B. Left
- C. Rear
- D. Center of installation to the DIN rail
- E. Bottom

Installation and Wiring

What's in This Chapter

Installation of Panel Mount Type	62
Installation of DIN Mount Type	69
Wiring the Power Supply	74
USB Cable Clamp	81
Front USB Cover	83
SD Card Installation	85
Expansion Unit	87
VESA Mounting	87
Isolation Unit Installation Procedure	90

Installation of Panel Mount Type

Precautions for Building into an End-use Product

This product is designed for use on flat surfaces of UL 50/50E, Type 1, Type 4X (indoor use only), Type 12 or Type 13 enclosure.

Mount this product in an enclosure that provides a clean, dry, robust and controlled environment (IP65F, IP66F, IP67F, UL 50/50E, Type 1, Type 4X [indoor use only], Type 12 or Type 13 enclosure).

For 10-inch wide, 12-inch wide, 15-inch wide, 19-inch wide and 22-inch wide models, the front surface is rated for IP66F, IP67F, UL 50/50E, Type 1, Type 4X (indoor use only), Type 12 and Type 13 enclosure.

For 10-inch, 12-inch and 15-inch models, when using a factory-installed front USB cover (without screw), the front surface is rated for IP65F, IP67F, UL 50/50E and Type 1 enclosures. When using a front USB cover (with screw) (PFXZCDCVUS1), the front surface is rated for IP66F, IP67F, UL 50/50E, Type 1, Type 4X (indoor use only), Type 12 and Type 13 enclosure.

Display front surface			Enclosure front surface
10-inch, 12-inch and 15-inch		10-inch wide/ 12-inch wide/ 15-inch wide/ 19-inch wide/ 22-inch wide	
Without screw	With screw		
IP65F, IP67F, UL 50/50E, Type 1	IP66F, IP67F, UL 50/50E, Type 1, Type 4X (indoor use only), Type 12, Type 13	IP66F, IP67F, UL 50/50E, Type 1, Type 4X (indoor use only), Type 12, Type 13	IP65F, IP66F, IP67F, UL 50/50E, Type 1, Type 4X (indoor use only), Type 12, Type 13

For 10-inch, 12-inch and 15-inch models, regardless of using a factory-installed front USB cover or a front USB cover with screw, when the front USB cover is open, the front surface is rated for UL 50/50E and Type 1 enclosure.

Be aware of the following when building this product into an end-use product:

- The rear face of this product is not approved as an enclosure. When building this product into an end-use product, be sure to use an enclosure that satisfies standards as the end-use product's overall enclosure.
- Install this product in an enclosure with mechanical rigidity.
- This product is not designed for outdoor use. UL certification obtained is for indoor use only.
- Install and operate this product with its front panel facing outward.

NOTE: IP65F, IP66F and IP67F are not part of UL certification.

Installation Requirements

⚠ CAUTION

RISK OF BURNING INJURY

- Do not touch the bezel or rear chassis during operation.
- Wear appropriate gloves when touching the front USB cover in ambient temperature above 45 °C (113 °F), or when operating the touch panel of the 15-inch wide model in ambient temperature above 50 °C (122 °F).

Failure to follow these instructions can result in injury or equipment damage.

- Check that the installation wall or cabinet surface is flat, in good condition and has no jagged edges. Metal reinforcing strips may be attached to the inside of the wall, near the panel cutout, to increase its rigidity.
- Decide on the thickness of the enclosure wall, based on the level of strength required. Even if the installation wall thickness is within the specified range, depending on the wall's material, size, and installation location of this product and other devices, the installation wall could warp. To prevent warping, the installation surface may need to be strengthened. For the specified wall thickness range, refer to *Panel Cutout Dimensions*, page 64.
- Check that the ambient air temperature and the ambient humidity are within their specified ranges in *Environmental Specifications (Panel Mount Type)*, page 39. When installing this product in a cabinet or enclosure, the ambient air temperature is the cabinet's or enclosure's internal and external temperature.

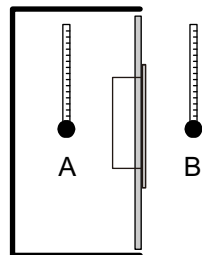

- A. Internal temperature
- B. External temperature

- Be sure that heat from surrounding equipment does not cause this product to exceed its standard operating temperature.
- When mounting this product in portrait orientation, ensure that the right side of this product faces up. In other words, the power connector on the DC model, or the power terminal block on the AC model, should be at the right.

NOTE: Please make sure your applications support portrait orientation of the display.

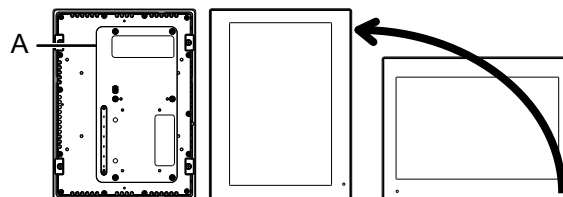

- A. Power connector

- When installing this product in a slanted position, the product face should not incline more than 30°.

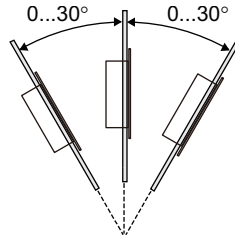

- For easier maintenance, operation and improved ventilation, install this product at least 100 mm (3.94 in) away from adjacent structures and other equipment as shown in the following illustration:

NOTE: Ensure that you have enough space to insert and remove the external storage.

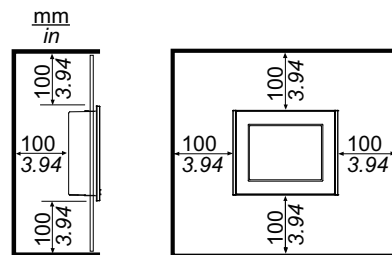

Pressure Differences

When applying and installing this product, it is important that steps are taken to eliminate any pressure difference between the inside and the outside of the enclosure in which this product is mounted. Higher pressure inside the enclosure can cause delamination of the front membrane of the display. Even a small pressure difference inside the enclosure will act on the large area of the membrane and can result in sufficient force to delaminate the membrane and thus cause failure of the touch capability. Pressure differences can often occur in applications where there are multiple fans and ventilators moving air at different rates in different rooms. Please follow these techniques to ensure that this product's function is not impacted by this mis-application:

- Seal all conduit connections inside of the enclosure, especially those that lead to other rooms that may be at a different pressure.
- Where applicable, install a small weep hole at the bottom of the enclosure to allow equalization of the internal and external pressure.

Panel Cutout Dimensions

This section lists the dimensions of the panel openings for installing the product.

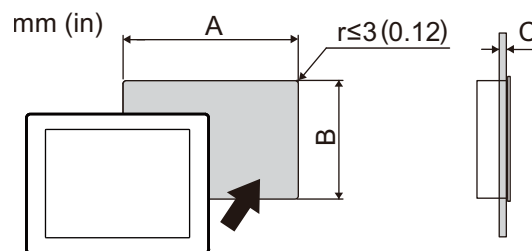



- A. Width
- B. Height

C. Panel thickness

The dimensional tolerance for the width and height of the panel cutout is +1/-0 mm (+0.04/-0 in). All the corners have a radius of R3 mm (R0.12 in) or less.

Model Name		
A	B	C
10-inch		
259 mm (10.2 in)	201 mm (7.91 in)	1.6...5 mm (0.06...0.2 in)
12-inch		
301.5 mm (11.87 in)	227.5 mm (8.96 in)	1.6...5 mm (0.06...0.2 in)
15-inch		
383.5 mm (15.1 in)	282.5 mm (11.12 in)	1.6...5 mm (0.06...0.2 in)
10-inch wide		
255 mm (10.04 in)	185 mm (7.28 in)	1.6...3 mm (0.06...0.12 in)
12-inch wide		
295 mm (11.61 in)	217 mm (8.54 in)	1.6...5 mm (0.06...0.2 in)
15-inch wide		
394 mm (15.51 in)	250 mm (9.84 in)	1.6...5 mm (0.06...0.2 in)
19-inch wide		
449.5 mm (17.7 in)	279.5 mm (11.0 in)	1.6...5 mm (0.06...0.2 in)
22-inch wide		
518.5 mm (20.41 in)	316.5 mm (12.46 in)	1.6...5 mm (0.06...0.2 in)

Installation Procedure



DANGER

HAZARD OF ELECTRIC SHOCK, EXPLOSION, OR ARC FLASH

- Remove all power from the device before removing any covers or elements of the system, and prior to installing or removing any accessories, hardware, or cables.
- Unplug the power cable from both this product and the power supply prior to installing or removing the product.
- Always use a properly rated voltage sensing device to confirm power is off where and when indicated.
- Replace and secure all covers or elements of the system before applying power to this product.
- Use only the specified voltage when operating this product. The DC model is designed to use 12 to 24 Vdc, and the AC model is designed to use 100 to 240 Vac. Always check whether your device is DC or AC powered before applying power.
- When using this product in Class I, Division 2, Groups A, B, C, and D hazardous locations, install this product in an enclosure that prevents the operator from touching the back of this product without the use of tools.

Failure to follow these instructions will result in death or serious injury.

NOTICE

EQUIPMENT DAMAGE

- Always use the installation gasket.
- Do not exert more torque than the amount specified.
- Keep this product stabilized in the panel cutout while you are installing or removing the installation screws or fasteners.

Failure to follow these instructions can result in equipment damage.

1. Check that the gasket is seated securely into the bezel's groove, which runs around the perimeter of the display panel frame.

NOTE: Always use the installation gasket, since it absorbs vibration in addition to repelling water. For the procedure on replacing the installation gasket, refer to [Replacing the Installation Gasket](#), page 94.
2. Cut the panel opening based on the specified [Panel Cutout Dimensions](#), page 64, and insert the product from the front of the opening.

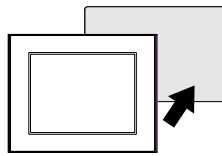

NOTE: This product has an anti-drop lock at the top to prevent it from falling. Insert the bottom part of the product into the panel opening, and then insert the top part while pressing the unlock button.

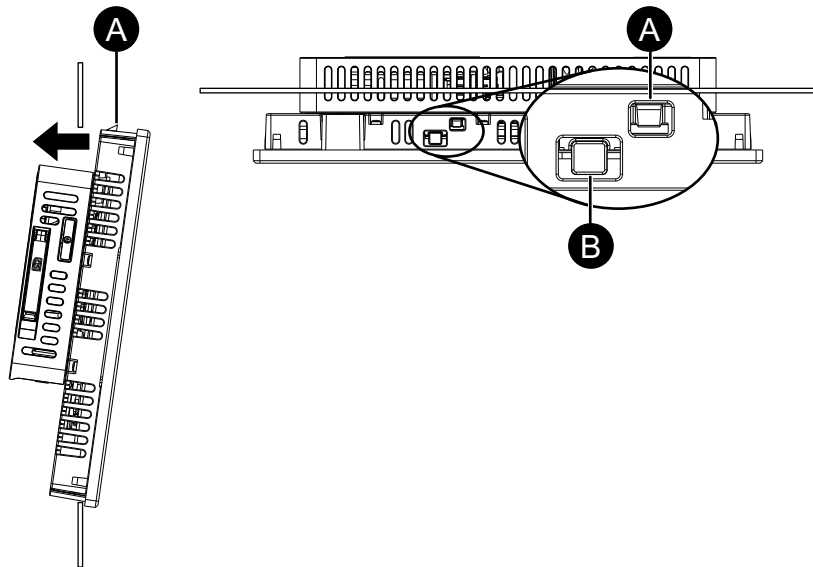

- A. Anti-drop lock
B. Unlock button

3. Insert the installation fasteners into the bracket openings at the top, bottom, left and right, and tighten the M4 screws little by little, alternating between diagonally-positioned screws.

NOTE: The necessary torque is 0.7 N•m (6.2 lb-in).

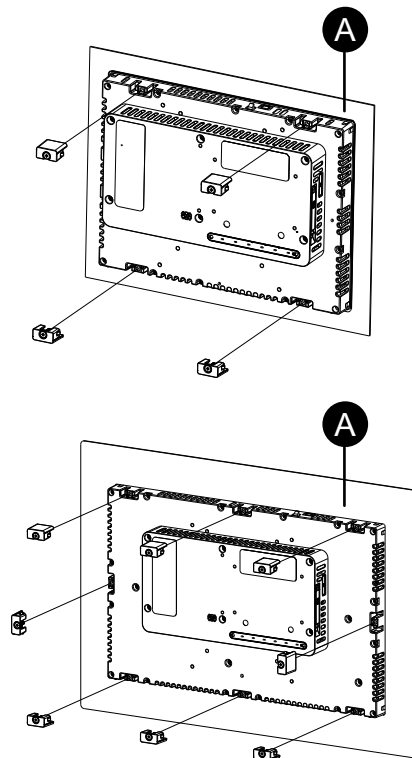

A. Panel

Number of Installation Fasteners

The number of installation fasteners for each model is as follows.

10-inch, 12-inch, 10-inch wide, 12-inch wide	Top - 2, Bottom - 2
15-inch, 15-inch wide, 19-inch wide, 22-inch wide	Top - 3, Bottom - 3, Left - 1, Right - 1

Removal Procedure

⚠️ ⚠️ DANGER

HAZARD OF ELECTRIC SHOCK, EXPLOSION, OR ARC FLASH

- Remove all power from the device before removing any covers or elements of the system, and prior to installing or removing any accessories, hardware, or cables.
- Unplug the power cable from both this product and the power supply prior to installing or removing the product.
- Always use a properly rated voltage sensing device to confirm power is off where and when indicated.

Failure to follow these instructions will result in death or serious injury.

▲ CAUTION**RISK OF INJURY**

Do not drop this product when you remove it from the panel.

- Hold this product in place after removing the fasteners.
- Use both hands.
- While pushing on the anti-drop lock, be careful not to hurt your fingers.

Failure to follow these instructions can result in injury or equipment damage.

NOTICE**EQUIPMENT DAMAGE**

- Keep this product stabilized in the panel cutout while you are installing or removing the screw fasteners.
- Remove this product while pushing the anti-drop lock or by making sure the lock does not touch the panel.

Failure to follow these instructions can result in equipment damage.

1. Loosen, in small increments, the M4 screws of installation fasteners in opposite corners to eventually remove the screws.

NOTE: For the number of installation fasteners on your model, refer to Number of Installation Fasteners in step 3 of Installation Procedure, page 65.

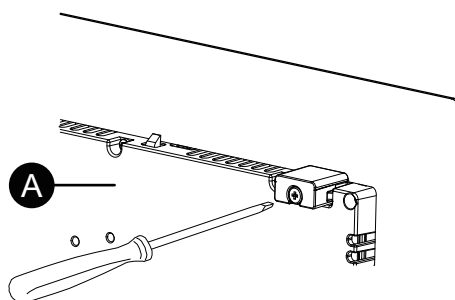

A. Rear side

2. Press the Unlock button at the top of the product to depress the anti-drop lock, then slowly remove the product from the panel.

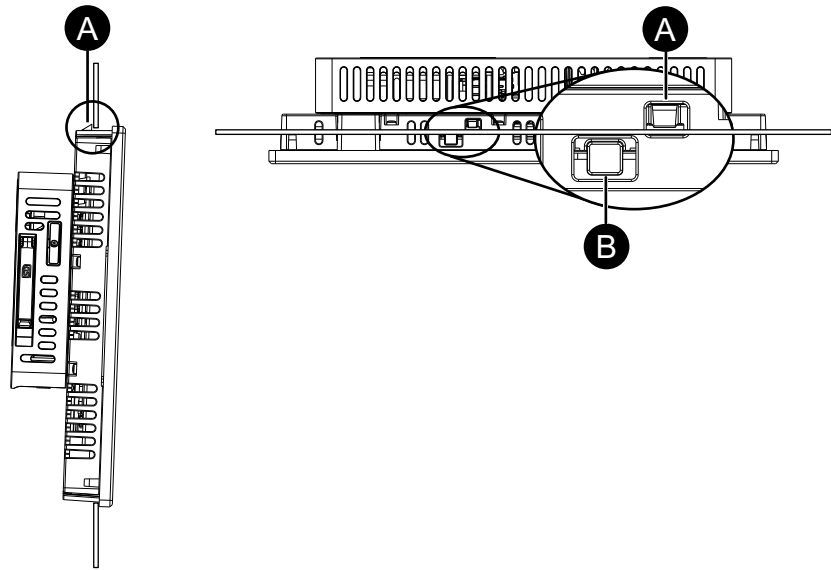

- A. Anti-drop lock
B. Unlock button

Installation of DIN Mount Type

Precautions for Installing onto an End-use Product

Be aware of the following when installing this product to an end-use product:

- This equipment is an open-type device and is meant to be installed in an enclosure suitable for the environment. Install in an enclosure where the equipment is inaccessible without the use of tools.
- Install this product in an enclosure with mechanical rigidity.

Installation Requirements (DIN Mount Type)

⚠ CAUTION

RISK OF BURNING INJURY

Wear appropriate gloves when touching the product in ambient temperatures greater than 45 °C (113 °F).

Failure to follow these instructions can result in injury or equipment damage.

- Check that the installation wall or cabinet surface is flat, in good condition and has no jagged edges. Metal reinforcing strips may be attached to the inside of the wall, near the installation location, to increase its rigidity.
- Depending on the wall's material, size, and installation location of this product and other devices, the installation wall could warp. To prevent warping, the installation surface may need to be strengthened.

- Check that the ambient air temperature and the ambient humidity are within their specified ranges in *Environmental Specifications (DIN Mount Type)*, page 43. When installing this product in a cabinet or enclosure, the ambient air temperature is the cabinet's or enclosure's internal and external temperature.

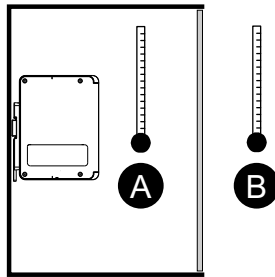

A. Internal temperature

B. External temperature

- Be sure that heat from surrounding equipment does not cause this product to exceed its standard operating temperature.
- For easier maintenance, operation and improved ventilation, install this product at least 100 mm (3.94 in) away from adjacent structures and other equipment as shown in the following illustration:

NOTE: Ensure that you have enough space to insert and remove the external storage.

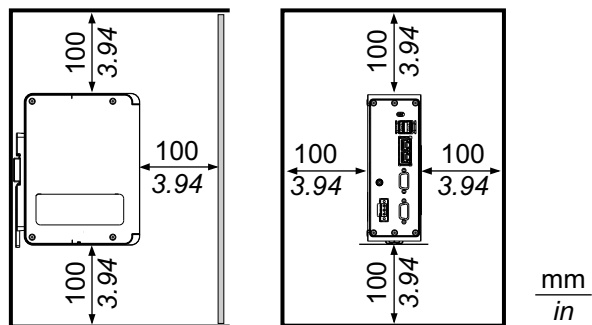

Installing onto DIN Rail

DANGER

HAZARD OF ELECTRIC SHOCK, EXPLOSION, OR ARC FLASH

- Remove all power from the device before removing any covers or elements of the system, and prior to installing or removing any accessories, hardware, or cables.
- Unplug the power cable from both this product and the power supply prior to installing or removing the product.
- Always use a properly rated voltage sensing device to confirm power is off where and when indicated.
- Replace and secure all covers or elements of the system before applying power to this product.
- Use only the specified voltage when operating this product. The DC model is designed to use 12 to 24 Vdc, and the AC model is designed to use 100 to 240 Vac. Always check whether your device is DC or AC powered before applying power.
- When using this product in Class I, Division 2, Groups A, B, C, and D hazardous locations, install this product in an enclosure that prevents the operator from touching the back of this product without the use of tools.

Failure to follow these instructions will result in death or serious injury.

NOTICE

EQUIPMENT DAMAGE

Do not exert more torque than the amount specified.

Failure to follow these instructions can result in equipment damage.

NOTE:

- Use the rail compatible with IEC 60715 TH35-7.5 for this product.
 - In environments where this product will experience vibration and shock, it is recommended to secure this product to the DIN rail with commercially available DIN rail end stoppers after installation.
1. With its backside facing up, place the product on a clean, flat, level surface.

2. Attach the DIN rail attachment included in the package to the product. Insert the two protrusions of the DIN rail attachment into the holes on the back of the product. Then, tighten with the four M4 screws included. The necessary torque is 0.7 N•m (6.2 lb-in).

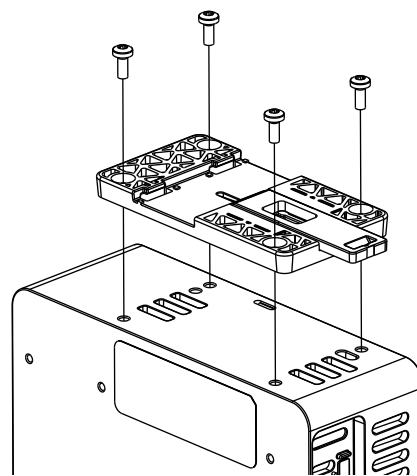
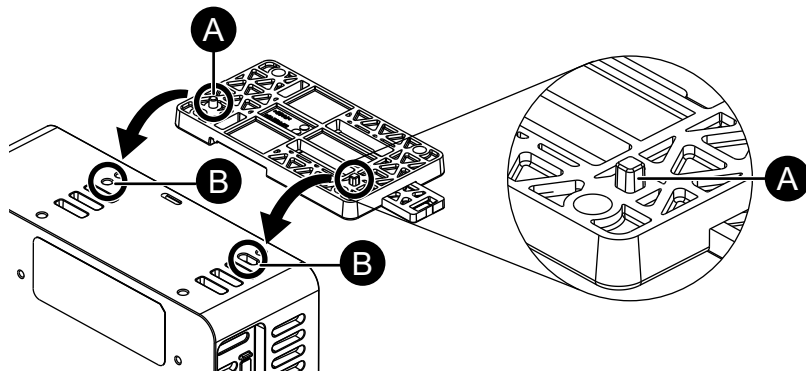

A. Protrusion

B. Holes

3. Hook the top groove of the DIN rail attachment to the top part of the DIN rail.

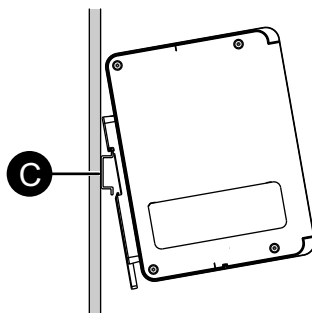

C. DIN rail

4. Push the bottom part onto the rail until you hear a click.

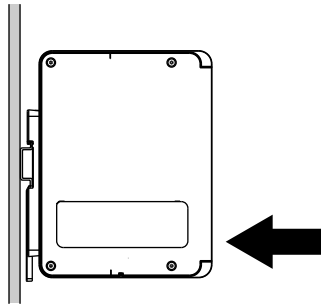

Removal from DIN Rail

⚡ ⚠ DANGER

HAZARD OF ELECTRIC SHOCK, EXPLOSION, OR ARC FLASH

- Remove all power from the device before removing any covers or elements of the system, and prior to installing or removing any accessories, hardware, or cables.
- Unplug the power cable from both this product and the power supply prior to installing or removing the product.
- Always use a properly rated voltage sensing device to confirm power is off where and when indicated.

Failure to follow these instructions will result in death or serious injury.

1. Using a tool such as a screwdriver, pull the hook in the direction indicated by the arrow.

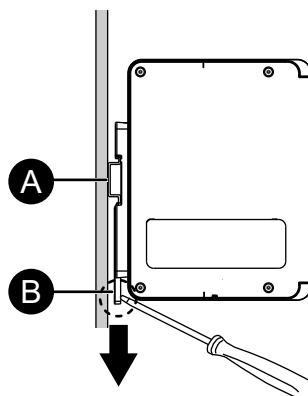

- A. DIN rail
B. Hook

2. Pull the bottom portion of this product forward to remove.

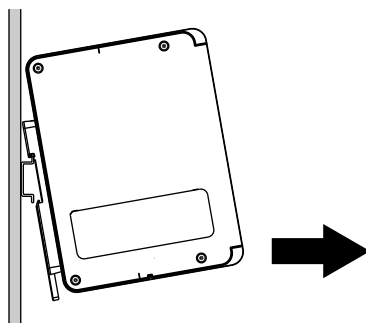

Wiring the Power Supply

AC/DC Power Cord Preparation

DANGER

HAZARD OF ELECTRIC SHOCK, EXPLOSION, OR ARC FLASH

- Remove all power from the device before removing any covers or elements of the system, and prior to installing or removing any accessories, hardware, or cables.
- Remove power before wiring this product's power terminals.
- Always use a properly rated voltage sensing device to confirm power is off where and when indicated.
- Replace and secure all covers or elements of the system before applying power to this product.
- Use only the specified voltage when operating this product. The DC model is designed to use 12 to 24 Vdc, and the AC model is designed to use 100 to 240 Vac. Always check whether your device is DC or AC powered before applying power.
- Since this product is not equipped with a power switch, be sure to connect a power switch to the power supply.
- Be sure to ground this product's PE/FG terminal.

Failure to follow these instructions will result in death or serious injury.

NOTE:

- The SG (signal ground) and PE/FG (protective earth/functional ground) terminals are connected internally in this product.
- When the PE/FG terminal is connected, be sure the wire is grounded. Not grounding this product can result in excessive electromagnetic interference (EMI).
- Make sure the ground wire is either the same or heavier gauge than the power wires.
- Do not use aluminum wires in the power supply's power cord.
- Use copper wire rated for 75 °C (167 °F) or higher.
- The conductor type of DC power cord is solid or stranded wire.
- If the ends of the individual wires are not twisted correctly, the wires may create a short circuit. When inserting a wire into the DC power connector, hold down the opening button and insert the wire while the internal spring is depressed. Alternatively, you can crimp and insert either a pin terminal or ferrule terminal.
- Use the SELV (Safety Extra-Low Voltage) circuit and LIM (Limited Energy) circuit for DC input.
- Use a maximum 20 A branch circuit protective device for AC input.
- AC models obtain UL certification for use in environments rated at Overvoltage Category II or lower.

Use a SELV (Safety Extra-Low Voltage) or LPS (Limited Power Source) for DC input.

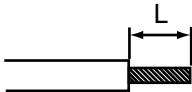
AC/	or
Power cord cross sectional area	0.75...3.5 mm ² (18...12 AWG)*1
Con	For DC input, a SELV (Safety Extra-Low Voltage) or LPS (Limited Power Source) power supply is required. Use of a Class 2 power supply is also acceptable.
Conductor length	10 mm (0.39 in)
	

AC/DC power cord	
Recommended screwdriver ^{*3}	SZS 0.6x3.5 (1205053)
Recommended pin terminals ^{*3}	3201288 AI 0,75 -10 GY 3200182 AI 1 -10 RD 3200195 AI 1,5 -10 BK 3202533 AI 2,5 -10 BU
Recommended pin terminal crimp tool ^{*3}	CRIMPFOX 6

*1 Thick wires are recommended to minimize voltage drops in the wire.

*2 When using stranded wires, confirm the allowable current of the wire.

*3 Items are manufactured by Phoenix Contact.

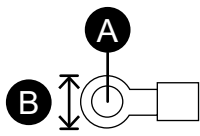
AC grounding wire	
Power cord cross sectional area	2 mm ² (14 AWG) or greater
Ring terminal size ^{*1}	 <p>A. $\Phi 4.3$ mm (0.17 in) or more B. 7.2 mm (0.28 in) or less</p>
Recommended ring terminal ^{*2}	V2-P4 V5.5-S4

*1 To prevent a short circuit caused by loose screws, use a crimp-type terminal with an insulating sleeve.

*2 Items are manufactured by J.S.T Mfg. Co., Ltd.

How to Connect the AC Power Cord

1. Confirm the power cord is not connected to the power supply.
2. Remove the M4 screw on the product's PE terminal, and with the ring terminal still attached, connect the grounding wire and tighten the screw.

NOTE:

- The necessary torque is 1.5 N•m (13.3 lb-in).
 - If the wire is not connected to the PE terminal properly, touch may not respond normally.
3. Crimp a pin terminal properly to the end of each power cable wire.
 4. Push the opening button with a small and flat screwdriver to open the desired pin hole.

5. Insert each power cord wire into its corresponding hole. Release the opening button to clamp the wire in place.

NOTE:

- When using stranded wire, do not short with neighboring wires.
- When connecting with stranded wires, do not solder the stranded wires.

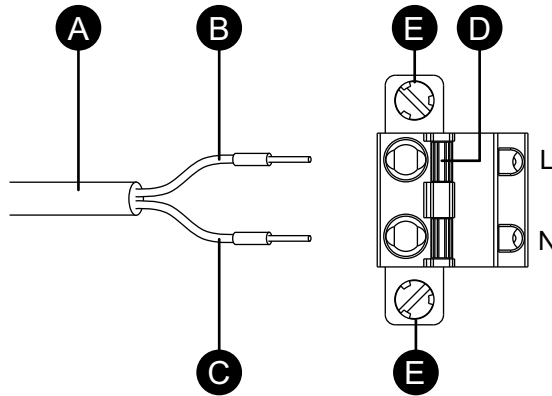

- A. Power cord
 B. Black
 C. White
 D. Opening button
 E. Screw

6. After inserting all two power cord wires, insert the AC power connector into the power connector on this product.
7. Tighten the screws on both sides of the connector to secure it.

NOTE: The necessary torque is 0.3 N•m (2.7 lb-in).

How to Connect the DC Power Cord

DC Power Connector: Spring Clamp Terminal Blocks

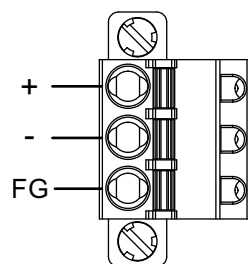

+	12...24 Vdc
-	0 Vdc
FG	Functional ground (Connect the FG terminal properly to ground.)

Connection Procedure

1. Confirm the power cord is not connected to the power supply.
2. Check the rated voltage and remove the "DC24V" sticker on the DC power supply connector.
3. Push the opening button with a small and flat screwdriver to open the desired pin hole.

4. Insert each power cord wire into its corresponding hole. Release the opening button to clamp the wire in place.

NOTE:

- When using stranded wire, do not short with neighboring wires.
- Do not solder the cable connection.

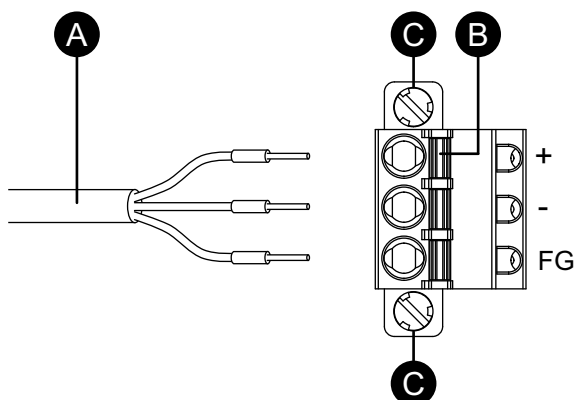

- A. Power cord
 B. Opening button
 C. Screw

5. After inserting all three power cord wires, insert the DC power connector into the power connector on this product.
6. Tighten the screws on both sides of the connector to secure it.

NOTE: The necessary torque is 0.3 N•m (2.7 lb-in).

Power Supply Precautions

⚠ DANGER

SHORT CIRCUIT, FIRE, OR UNINTENDED EQUIPMENT OPERATION

- Install and fasten this product in an installation panel or cabinet prior to connecting power supply and communication lines.
- Securely attach power cables to an installation panel or cabinet.
- Avoid excessive force on the power cable.

Failure to follow these instructions will result in death or serious injury.

- This product's power cord should not be bundled with or kept close to main circuit lines (high voltage, high current), power lines, or input/output lines, and their various systems should be kept separate. When power lines cannot be wired via a separate system, use shielded cables for input/output lines.
- An independent DC power supply is recommended on the DC model. (The DC power supply should be located close to the product.)
- If there is an excess amount of noise on the power supply line, reduce the noise with a noise filter before turning on the power.
- Connect a surge protection device to handle power surges.
- To increase noise resistance, attach a ferrite core to the power cable.

Power Supply Connections

- Use the SELV (Safety Extra-Low Voltage) circuit and LIM (Limited Energy) circuit for DC input.

- If the voltage variation is outside the prescribed range, connect a regulated power supply.

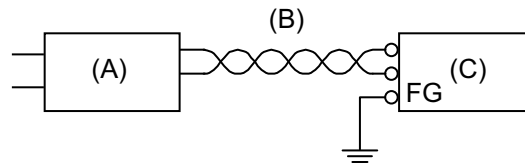

- A. Regulated power supply
- B. Twisted-pair cord
- C. This product

For AC model

- Select a power supply, low in noise, for between the line and ground. If there is an excess amount of noise, connect an insulating transformer. Use constant voltage and insulating transformers with capacities that exceed the Power Consumption value.

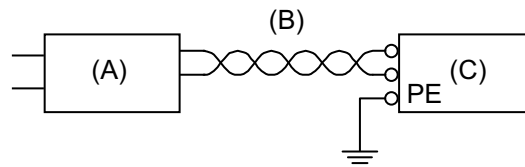

- A. Insulating transformer
- B. Twisted-pair cord
- C. This product

- The following shows a surge protection device connection:

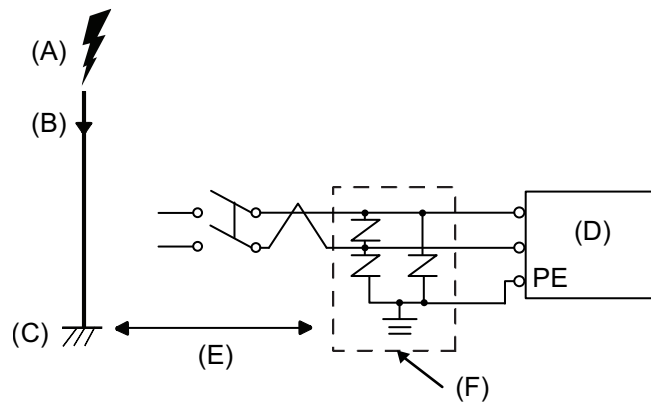

- A. Lightning
- B. Lightning rod
- C. Ground
- D. This product
- E. Provide adequate distance
- F. Surge protection device

- Attach a surge protection device to prevent damage to this product as a result of a lightning induced power surge from a large electromagnetic field generated from a direct lightning strike. We also strongly recommend to connect the crossover grounding wire of this product to a position close to the ground terminal of the surge protection device.

It is expected that there will be an effect on this product due to fluctuations in grounding potential when there is a large surge flow of electrical energy to the lightning rod ground at the time of a lightning strike. Provide adequate distance between the lightning rod grounding point and the surge protection device grounding point.

Grounding

Independent Grounding

Always ground the PE/FG (protective earth/functional ground) terminal. Be sure to separate this product from the PE/FG of other devices as shown below.

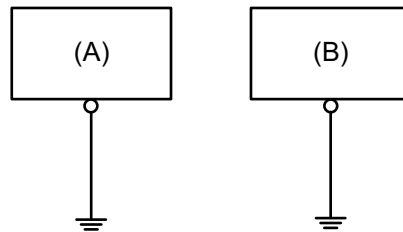

- A. This product
- B. Other device

Precautions

- Check that the grounding resistance is 100 Ω or less.*1
- The PE/FG wire should have a cross sectional area 2 mm² (14 AWG) or greater*1. Create the connection point as close as possible to this product, and make the wire as short as possible. When using a long grounding wire, replace the thin wire with a thicker wire, and place it in a duct.
- The SG and PE/FG terminals are connected internally in this product. When connecting the SG line to another device, be sure that no ground loop is formed.

*1 Observe local codes and standards.

Common Grounding

Electromagnetic Interference (EMI) can be created if devices are improperly grounded. EMI can cause loss of communication. If independent grounding is not possible, use a common grounding point as shown in the configuration below. Do not use any other configuration for common grounding.

Correct grounding

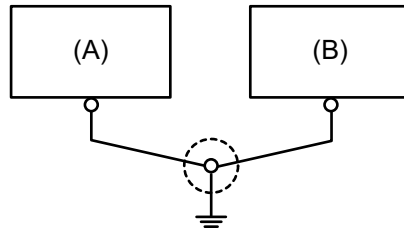

A. This product

B. Other device

Incorrect grounding

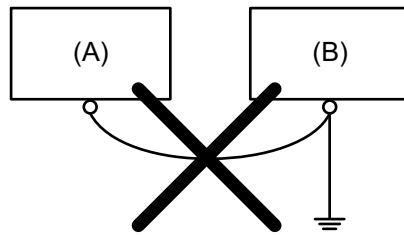

A. This product

B. Other device

USB Cable Clamp

Precautions for Connecting the USB Cable

⚠ WARNING

EXPLOSION HAZARD

- Verify the power, input, and output (I/O) wiring are in accordance with Class I, Division 2 wiring methods.
- Do not use this product in hazardous environments or locations other than Class I, Division 2, Groups A, B, C, and D.
- Substitution of any components may impair suitability for Class I, Division 2.
- Do not disconnect equipment while the circuit is live or unless the area is known to be free of ignitable concentrations.
- Remove power before attaching or detaching any connectors to or from this product.
- Ensure that power, communication, and accessory connections do not place excessive stress on the ports. Consider the vibration in the environment when making this determination.
- Securely attach power, communication, and external accessory cables to the panel or cabinet.
- Use only commercially available USB cables.
- Use only non-incendive USB configurations.
- Suitable for use in Class I, Division 2, Groups A, B, C, D Hazardous Locations.
- Confirm that the USB cable has been attached with the USB cable clamp before using the USB interface.

Failure to follow these instructions can result in death, serious injury, or equipment damage.

Attaching USB Clamp Type-A

When using a USB device, attach a USB cable clamp to the USB interface to prevent the USB cable from being disconnected.

NOTE: Watch your fingers. The edge of the clip is sharp.

1. Mount the clip to the USB mark  connector shell so that it overlaps. The clip matches the 27 to 43.5 mm (1.06 to 1.71 in) length of the USB connector.

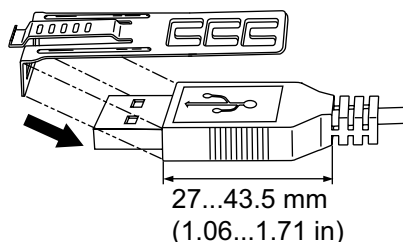

- Align the clip and the USB cable connector shell. Adjust the position of the holes where the clip is attached. To ensure stability, select the clip-hole position that is closest to the base of the connector shell.

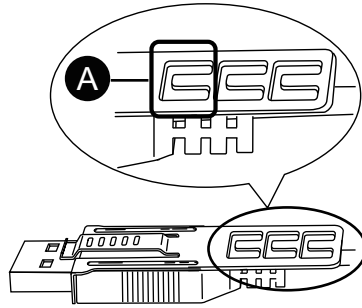

A. Hole for tie to pass through

- As shown, pass the tie through the clip hole. Next, turn the tie and pass it through the head so that the USB cable can pass through the center of the tie loop. The clip is now attached to the USB cable.

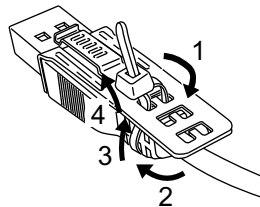

NOTE:

- Check the direction of the head beforehand. Make sure the USB cable is through the center of the tie loop and that the tie can pass through the head.
 - When attaching the cable clamp for USB port 2, make sure the head is on the cable side and not the clip side.
 - You can substitute the tie provided with PFXZCBCLUSA1, or other commercially available ties with a width of 4.8 mm (0.19 in) and thickness of 1.3 mm (0.05 in).
- While pressing the grip on the clip, insert the cable from step 3 all the way into the USB host interface. Make sure that the clip tab is secured to the USB cable attached to this product.

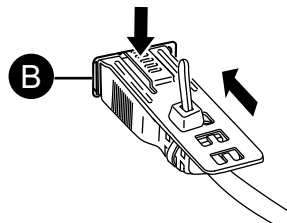

B. USB Type-A interface

Removing USB Clamp Type-A

Remove the USB cable while pushing the grip section of the clip.

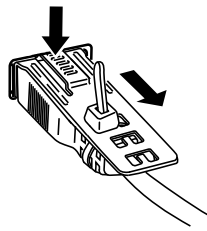

If you use the panel mount type and both USB ports 1 and 2 have USB cables with clamps, remove the cable first from USB port 1.

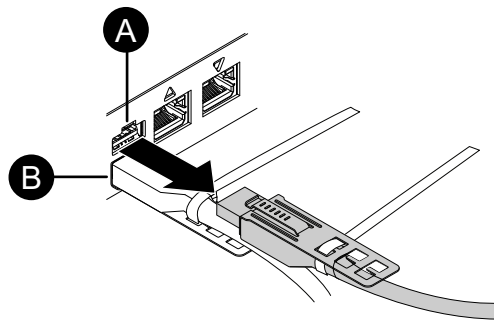

A. USB port 1

B. USB port 2

Removing USB Cable from USB Port 2

Cut or loosen the cable tie of the USB port 2 clamp, remove the USB cable first, and then remove the USB clamp.

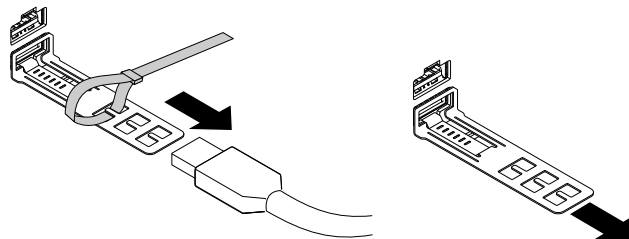

Alternatively, pull the USB cable out along with the clamp while pressing down on the grip part of the clip, using a tool such as a screwdriver.

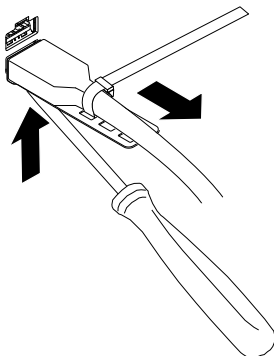

Front USB Cover

Opening the Front USB Cover

For 10-inch, 12-inch and 15-inch models, when using a factory-installed front USB cover (without screw), the front surface is rated for IP65F, IP67F, UL 50/50E, or Type 1 enclosure. When using a front USB cover (with screw) (PFXZCDCVUS1), the front surface is rated for IP66F, IP67F, UL 50/50E, Type 1, Type 4X (indoor use only), Type 12 and Type 13 enclosure.

Regardless of using a factory-installed front USB cover or a front USB cover with screw, when the cover is open, the front surface is rated for UL 50/50E and Type 1 enclosure.

NOTE: IP65F, IP66F and IP67F are not part of UL certification.

⚠ CAUTION

RISK OF INJURY

When opening the Front USB Cover, be careful not to injure your fingers.

Failure to follow these instructions can result in injury or equipment damage.

NOTICE

EQUIPMENT DAMAGE

Do not exert more torque than the amount specified.

Failure to follow these instructions can result in equipment damage.

1. Place your finger or a tool (such as a screwdriver) in the gap on the top of the front USB cover and pull out as illustrated.

NOTE:

- When using front USB cover (PFXZCDCVUS1), loosen a top M3 screw.
- The necessary torque is 0.5 N•m (4.4 lb-in).

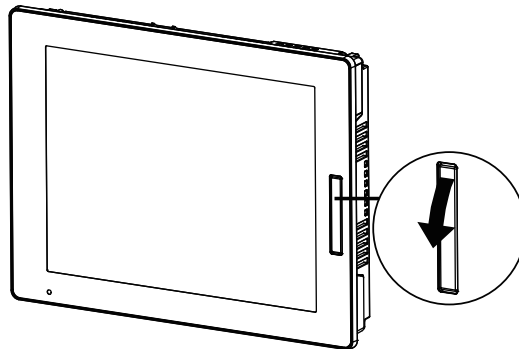

2. The USB interface can be seen once you pull out the front USB cover.

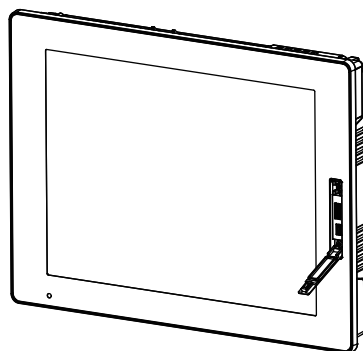

SD Card Installation

Precaution When Handling the SD Card

NOTICE

LOSS OF DATA

When using a SD card:

- Make sure you regularly back up the SD card data.
- While a SD card is accessed, do not turn off or reset this product, and do not remove the SD card.
- Before removing the SD card from this product, stop all operations on the SD card.
- Make sure of the SD card's orientation before inserting it into the SD card slot.

Failure to follow these instructions can result in equipment damage.

NOTICE

LOSS OF DATA

When handling the SD card:

- Avoid storing the SD card where there is static electricity or electromagnetic waves.
- Avoid storing the SD card in direct sunlight, near a heater, or other locations where high temperatures can occur.
- Do not bend the SD card.
- Do not drop or strike the SD card against another object.
- Keep the SD card dry.
- Do not touch the SD card connectors.
- Do not disassemble or modify the SD card.
- Use only SD cards formatted with the specified file system.

Failure to follow these instructions can result in equipment damage.

The file systems that this product supports are FAT, FAT32, and exFAT. This product does not recognize external storage formatted with NTFS.

Inserting the SD Card

NOTE: As shown in the image below (example on the left-hand side), you can set the Write-Control Tab to prevent write operations to the SD card. Push the tab up, as shown in the example on the right-hand side, to release the lock and enable writing to the SD card. Before using a commercial-type SD card, read the manufacturer's instructions.

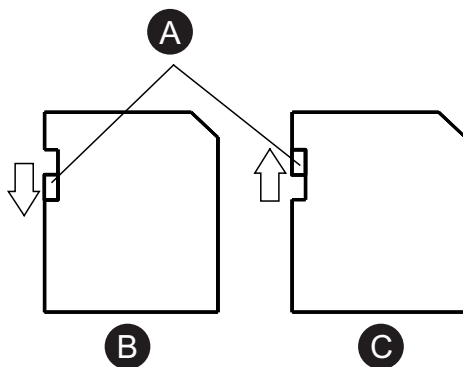

- A. Write-control tab
- B. Write disabled (enable to read)
- C. Write enabled

1. Touch the housing or ground connection (not the power supply) to discharge any electrostatic charge from your body.
2. Open the SD card slot cover. To open, lightly push the edge of the cover in the direction of the arrow.

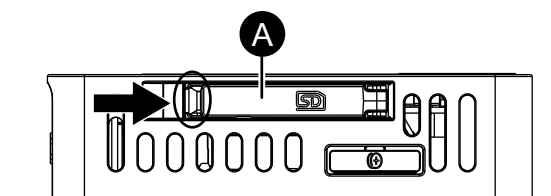

- A. SD card slot cover

3. Insert the SD card into the SD card slot with the front face of the SD card facing up.

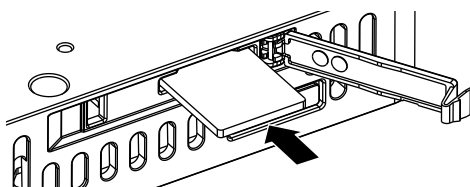

4. Push until you hear it "click".
5. Close the SD card slot cover.

Removing the SD Card

If you remove the SD card while it is in use, you risk corrupting the data. Before removing the SD card from this product, stop all operations on the SD card.

1. Make sure the SD card access LED is off, then open the SD card slot cover. To open the slot cover, lightly push the edge of the cover in the direction of the arrow.

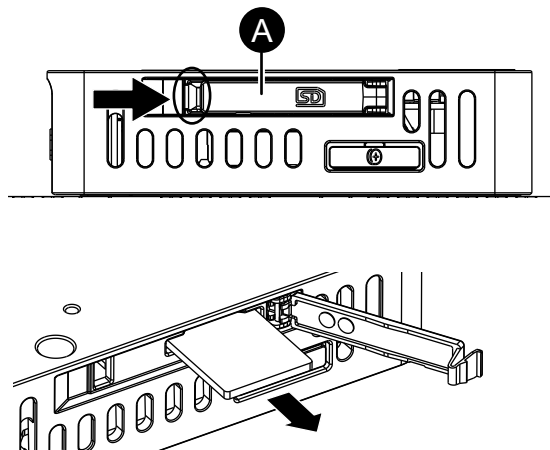

A. SD card slot cover

NOTE:

- When using a DIN Mount Type, open the SD card cover to find the SD card eject button. Press the eject button to **Safely Remove Hardware**. When this product and the SD card are disconnected, the SD card access LED turns off.
- Do not hold down the SD card eject button. If you press and hold the eject button, the product will reboot. For more information, refer to Eject Button, page 53.

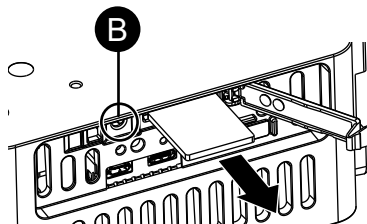

B. SD card eject button

2. Push the SD card once to release, then pull out the card.

NOTE: After using the SD card, store the SD card in its case or in another safe location.

3. Close the SD card slot cover.

Expansion Unit

For instructions on installing the expansion unit, refer to Expansion Unit Hardware Guide.

Related Documents, page 11

VESA Mounting

By attaching the optional VESA mounting plate, you can mount the product to commercially available monitor arms or wall-mount adapters that comply with the VESA standard (100 x 100 mm [3.93 x 3.93 in]).

Model number: HMIZHVESA

NOTE:

- VESA mounting is not covered by UL certification, marine classification standards, explosion-proof standards, RCM compliance, or other such certifications/standards.
- Before you install this optional accessory, confirm specifications such as the wall strength and the load capacity of the intended monitor arm.
- Verify that the mechanical specifications, such as vibration resistance and shock resistance, are appropriate for your installation environment.

Package Contents

Verify all items listed here are present in your package.

If you find anything damaged or missing, please contact customer support immediately.

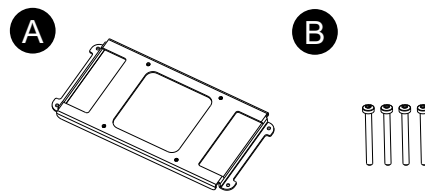

- A. VESA mounting plate x 1
 B. M3 screw (length: 39 mm [1.53 in]) x 4

External Dimensions

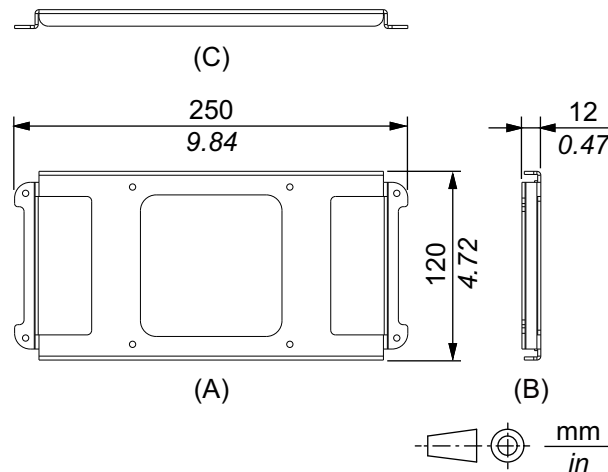

- A. Front
 B. Left
 C. Bottom

Attaching the VESA Mounting Plate

NOTICE

EQUIPMENT DAMAGE

Do not exert more torque than the amount specified.

Failure to follow these instructions can result in equipment damage.

1. Place the product on a clean and level surface with the screen facing down.
2. Remove the four screws on the rear face.
M3 screws, length: 30 mm (1.18 in)

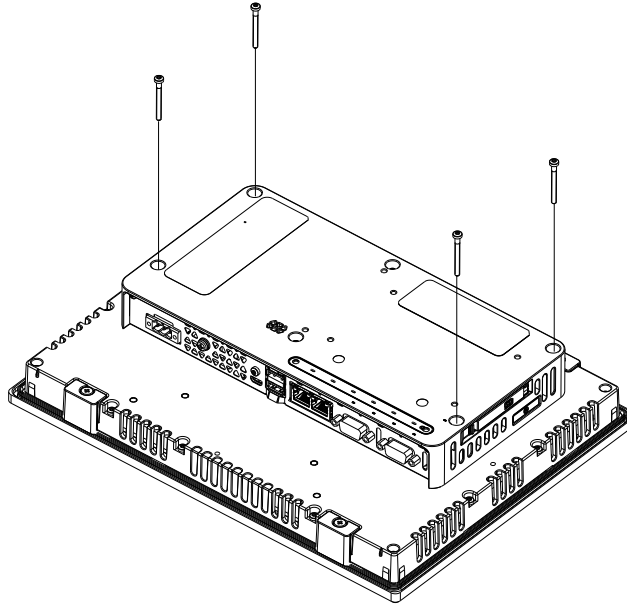

3. Align the screw holes on the VESA mounting plate with the screw holes on the BOX module, then secure the plate using the four screws included in the package.

M3 screw, length: 39 mm (1.53 in)

NOTE:

- Please use the correct screws.
- The necessary torque is 0.5 N•m (4.4 lb-in).

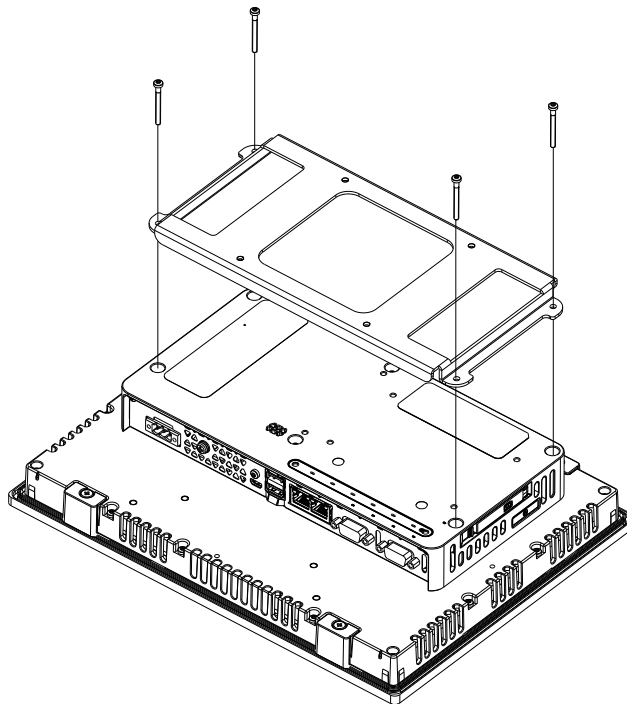

Mounting/Removing the Product on Monitor Arm

Use the four M4 screws to attach the product to the commercially available monitor arm or wall-mount adapter.

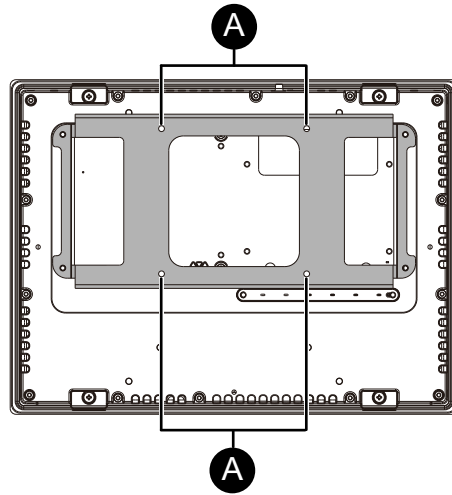

A. VESA mounting screw holes

- The effective thread depth of the screw holes on the VESA mounting plate is 10 mm (0.39 in) or less.
- The maximum tightening torque is 1.0 N•m (8.9 lb-in). Please check the specified torque values for the arm or adapter you are using, and tighten the screws to the appropriate torque.

⚠ CAUTION

RISK OF INJURY, EQUIPMENT DAMAGE

- Do not drop the product when installing or removing it from the monitor arm or wall-mount adapter.
- Use both hands to firmly support the product when installing or removing it.
- Regularly confirm that all screws and mounting brackets are securely fastened.

Failure to follow these instructions can result in injury or equipment damage.

Isolation Unit Installation Procedure

You can install the Isolation Unit to the back of this product or to the installation panel. For details such as settings when using the Isolation Unit, refer to the product manual.

⚡ ⚠ DANGER

HAZARD OF ELECTRIC SHOCK OR EXPLOSION

Prior to connecting the Isolation Unit to this product, confirm that this product's power supply is completely turned OFF.

Failure to follow these instructions will result in death or serious injury.

NOTICE

EQUIPMENT DAMAGE

Do not exert more torque than the amount specified.

Failure to follow these instructions can result in equipment damage.

NOTE:

- Install the Isolation Unit to a stable surface.
 - Do not leave the Isolation Unit hanging by its cord.
 - Be careful with wire placement. Overlapping cords may cause noise.
1. Check the locations of two screw holes on the rear of this product.

Panel mount type

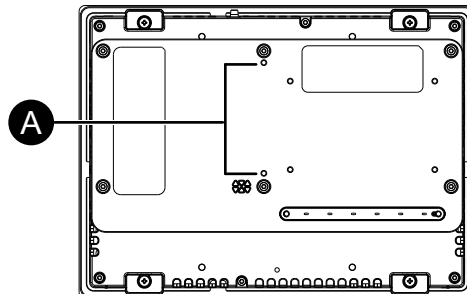

DIN mount type

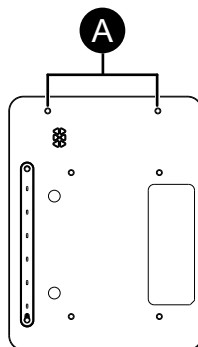

A. Screw holes

2. Install one of the two attachment screws included in the Isolation Unit to this product. Use a torque of 0.5 N•m (4.4 lb-in).

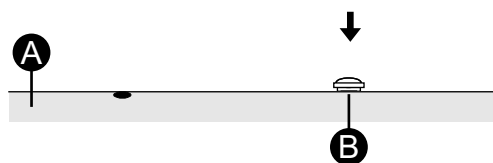

A. This product

B. Attachment screw

3. Attach the Isolation Unit to this product.

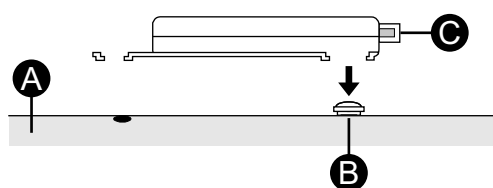

A. This product

B. Attachment screw

C. Isolation unit

- Slide the Isolation Unit in the direction of the arrow so the Isolation Unit is hooked by the screw from Step 2.

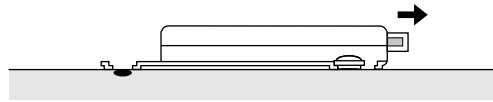

- Secure the Isolation Unit in place with another attachment screw. Use a torque of 0.5 N•m (4.4 lb-in).

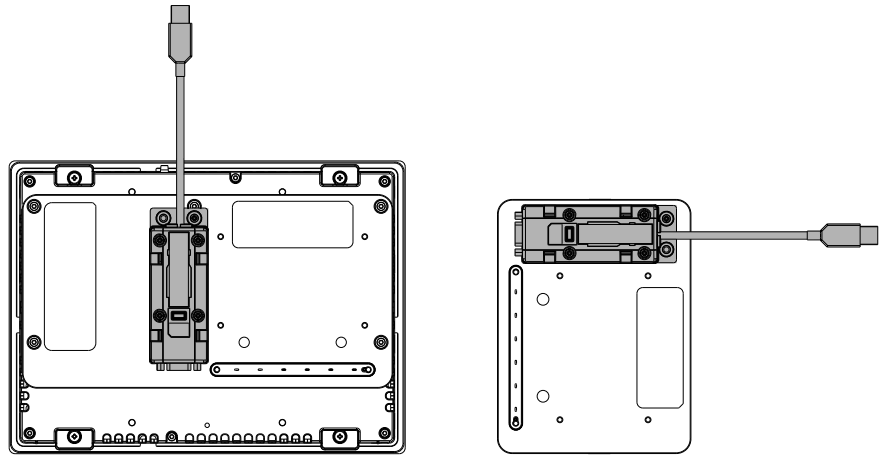
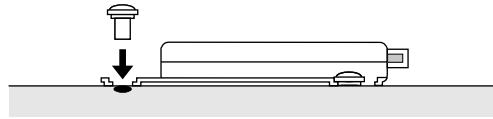

Maintenance

What's in This Chapter

Regular Cleaning	93
Periodic Check Points.....	93
Replacing the Installation Gasket.....	94
Replacing the Display Module or Box Module	94
Replacing the Battery	97
After-sales Service	98

Regular Cleaning

Cleaning This Product

NOTICE

EQUIPMENT DAMAGE

- Power off this product before cleaning it.
- Do not use hard or pointed objects to operate the touch panel.
- Do not use paint thinner, organic solvents, or a strong acid compound to clean the unit.

Failure to follow these instructions can result in equipment damage.

When this product gets dirty, wipe this product with a soft, dry cloth or a soft cloth soaked in only water and wrung tightly.

NOTE: When the product is very dirty, soak the soft cloth in water with a neutral detergent, wring the cloth tightly and wipe the product while avoiding the product label.

Periodic Check Points

Operation Environment

- Is the ambient air temperature within the allowable range? Refer to followings:
Environmental Specifications (Panel Mount Type), page 39
Environmental Specifications (DIN Mount Type), page 43
- Is the ambient air humidity within the specified range? Refer to followings:
Environmental Specifications (Panel Mount Type), page 39
Environmental Specifications (DIN Mount Type), page 43
- Is the operating atmosphere free of corrosive gasses?

When this product is inside a panel, the ambient environment refers to the interior of the panel.

Electrical Specifications

- Is the input voltage appropriate? Refer to followings:
Electrical Specifications (Panel Mount Type), page 36
Electrical Specifications (DIN Mount Type), page 42

- Are all power cords and cables connected properly? Are there any loose cables?
- Are all installation fasteners holding the unit securely?
- Are there scratches or traces of dirt on the installation gasket?

Unit Disposal

When disposing this product, dispose it in a manner appropriate to, and in accordance with, your country's industrial machinery disposal/recycling standards.

Replacing the Installation Gasket

The installation gasket provides protection against dust and moisture. The gasket must be inserted correctly into the groove for moisture resistance for this product.

NOTICE

EQUIPMENT DAMAGE

- Inspect the gasket periodically as required by your operating environment.
- Replace the gasket at least once a year, or as soon as scratches or dirt become visible.
- Be careful not to stretch the gasket unnecessarily.

Failure to follow these instructions can result in equipment damage.

1. Place the product on a flat, level surface, with the display face pointing down.
2. Remove the gasket from the product.
3. Attach the new gasket to the product. Insert the protrusions from the four corners of the gasket into the corresponding holes in the corners of the product. Depending on your model, there may be additional protrusions. In the following, refer to the figure on the right and insert the protrusions accordingly.

NOTE: When using a tool to insert the gasket, make sure the tool does not catch the rubber gasket and cause a tear.

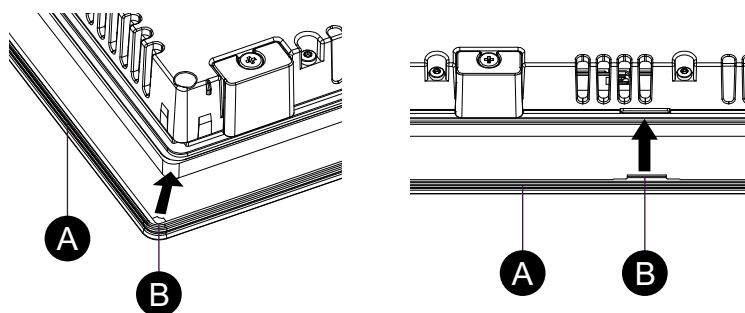

A. Installation gasket

B. Protruding point

Replacing the Display Module or Box Module

When using the Panel Mount Type, you can replace the Display Module with the same display type.

For replacement products, refer to the [Maintenance Accessories](#), page 25.

⚠ ⚠ DANGER**HAZARD OF ELECTRIC SHOCK, EXPLOSION, OR ARC FLASH**

- Remove all power from the device before removing any covers or elements of the system, and prior to installing or removing any accessories, hardware, or cables.
- Unplug the power cable from both this product and the power supply prior to installing or removing the product.
- Always use a properly rated voltage sensing device to confirm power is off where and when indicated.
- Replace and secure all covers or elements of the system before applying power to this product.
- Use only the specified voltage when operating this product. The DC model is designed to use 12 to 24 Vdc, and the AC model is designed to use 100 to 240 Vac. Always check whether your device is DC or AC powered before applying power.

Failure to follow these instructions will result in death or serious injury.

Removing the Display Module

⚠ CAUTION**RISK OF INJURY, EQUIPMENT DAMAGE**

Do not drop the Box Module when you remove it from the product.

- Do not remove the Box Module while the product is attached to the panel.
- Hold this product in place after removing the screws.
- Use both hands.

Failure to follow these instructions can result in injury or equipment damage.

1. Place the product on a clean and level surface with the screen facing down.
2. Remove the six screws on the rear face, then remove the Box Module.
M3 screw, length: 30 mm (1.18 in)

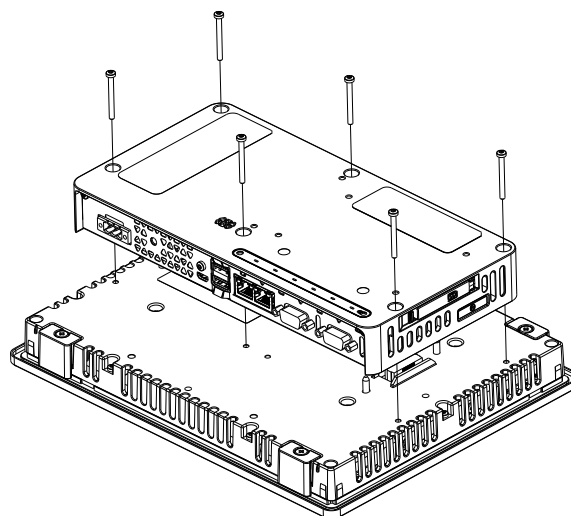

Installing the Display Module

NOTICE

EQUIPMENT DAMAGE

Do not exert more torque than the amount specified.

Failure to follow these instructions can result in equipment damage.

1. Place the Display Module on a clean and level surface with the screen facing down.
2. Cover the Box Module so that its outline fits in the appropriate guidelines and you can enter the installation pins through the holes.

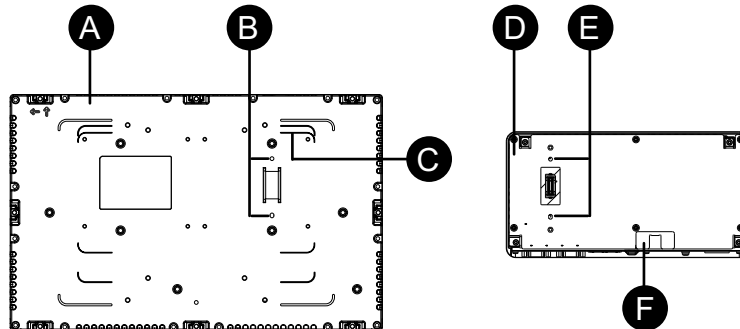

- A. Display module (rear)
- B. Installation pins
- C. Guideline
- D. Box module (rear)
- E. Pin holes
- F. Security seal*1

*1 Do not remove the security seal. For details, refer to Security Seal, page 13.

3. Tighten the six screws to attach the Box Module.

M3 screw, length: 30 mm (1.18 in)

NOTE: The necessary torque is 0.5 N•m (4.4 lb-in).

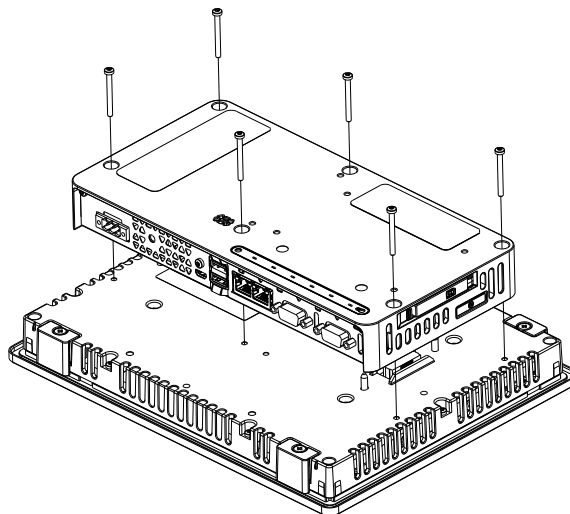

Replacing the Battery

This product uses a primary (non-rechargeable) battery for data backup of the internal clock. If the battery is depleted, the clock data will be lost. Use only the BR2032 (manufactured by Panasonic Corporation) battery as a replacement.

DANGER

HAZARD OF ELECTRIC SHOCK, EXPLOSION, OR ARC FLASH

- Follow the procedures step by step to replace the battery correctly and safely.
- Before replacing the battery, turn off this product's power.

Failure to follow these instructions will result in death or serious injury.

DANGER

EXPLOSION, FIRE, OR CHEMICAL HAZARD

- Use only the identical replacement battery for this product.
- Do not cause a short circuit.
- Recycle or properly dispose of used batteries.
- Do not recharge, disassemble or heat above 80 °C (176 °F).
- Use your hands or insulated tools to remove or replace the battery.
- Maintain proper polarity when inserting and connecting a new battery.

Failure to follow these instructions will result in death or serious injury.

NOTICE

LOSS OF DATA

- Replace the battery regularly every five years after you purchase this product.
- Insert the battery before reconnecting the power supply.
- Allow only qualified personnel to replace the battery.

Failure to follow these instructions can result in equipment damage.

NOTE:

- Insert the battery before reconnecting the power supply. Otherwise, the clock will not work properly.
- After reconnecting the power supply, set up the clock again. Refer to your screen editing software manual on how to set up the clock.

Battery replacement procedure

1. Disconnect the power supply from this product.
2. Touch the housing or ground connection to discharge any electrostatic charge from your body.
3. Place the product face down on a clean, flat, level surface.

4. Insert a flat head screwdriver into the groove of the battery slot to pull it out.

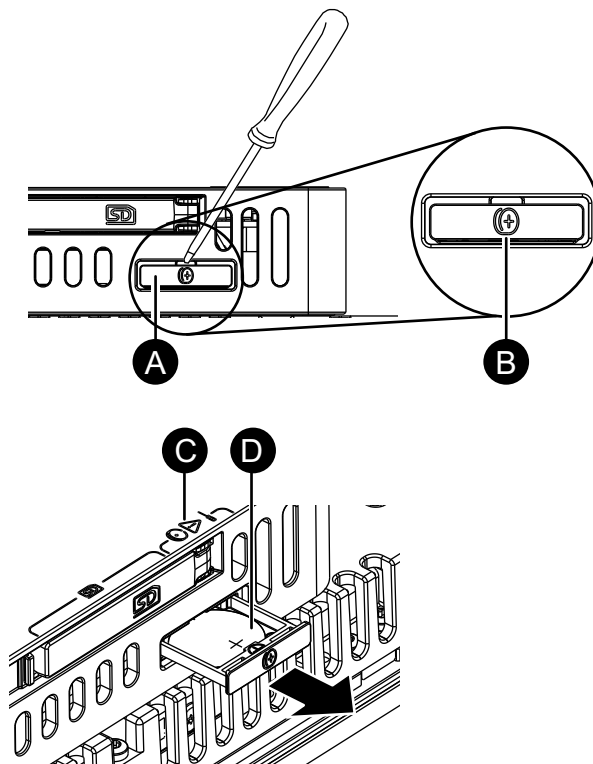

- A. Battery slot
- B. Battery symbol
- C. Safety alert symbol (see the previous safety messages)
- D. Battery

5. Remove the spent battery from the tray by touching the battery from the bottom.

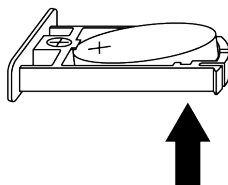

6. Put the new battery on the tray in accordance with the polarity markings in the tray and on the battery.
7. Insert the tray into the battery slot.
8. Reconnect the power supply to this product.

After-sales Service

For details on after-sales service, refer to our website.

<https://www.pro-face.com/trans/en/manual/1015.html>

Schneider Electric Japan Holdings Ltd.

4-4-9 Kitahama, Chuo-ku
Osaka, 541-0041 Japan

+ 81 (0) 50 4561 4800

www.pro-face.com

As standards, specifications, and design change from time to time, please ask for confirmation of the information given in this publication.

© 2026 – Schneider Electric Japan Holdings Ltd. All rights reserved.

GP6000-MM01-EN.01