

SIMATIC S7 3964(R)/ RK512 Driver

1	System Configuration.....	3
2	Selection of External Device	7
3	Example of Communication Setting.....	8
4	Setup Items	20
5	Cable Diagram	25
6	Supported Device.....	30
7	Device Code and Address Code.....	31
8	Error Messages.....	32

IMPORTANT

- The below Displays are no longer sold nor maintained by Pro-face. To reduce unplanned downtime due to aged hardware and to maximize your cyber security environment we recommend replacing your devices with a new, successor model. For details, please visit our homepage for "Recommended Substitution".
Discontinued from GP-Pro EX 5.00 onwards: GP3000 Series, GP-4100 Series (Monochrome model), LT3000 Series, ST3000 Series, PL Series, PE4000 Series, PS2000/3000/4000 Series.
- For details on the Displays supported by the driver, please check the "Connectable Devices" on our website.
<http://www.pro-face.com/trans/en/manual/1064.html>

Introduction

This manual describes how to connect the Display and the External Device (target PLC).

In this manual, the connection procedure will be described by following the below sections:

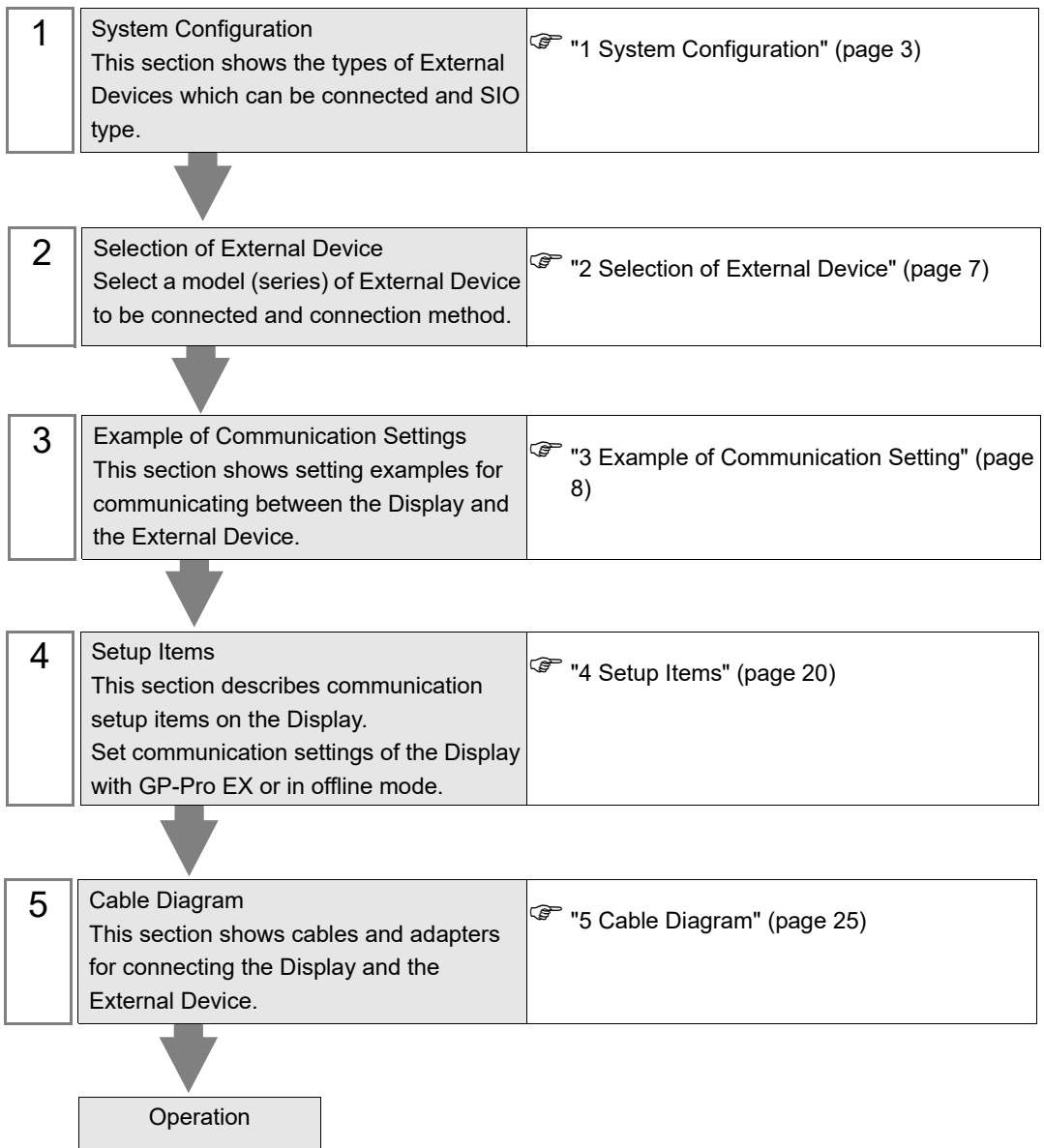

1 System Configuration

The system configuration in the case when the External Device of Siemens AG and the Display are connected is shown.

Series	CPU Module	Link I/F	SIO Type	Setting Example	Cable Diagram
SIMATIC S7-300 Series	CPU312IFM CPU313 CPU314	CP341 (RS232C)	RS232C	Setting Example 1 (page 8)	Cable Diagram 1 (page 25)
	CPU314IFM CPU315 CPU315-2 DP CPU316 CPU316-2 DP CPU318-2	CP341 (RS422/ 485)	RS422/485 (4wire)	Setting Example 2 (page 11)	Cable Diagram 2 (page 27)
SIMATIC S7-400 Series	CPU412-1 CPU412-2 DP CPU413-1	CP441-2 + IF963-RS232	RS232C	Setting Example 3 (page 14)	Cable Diagram 1 (page 25)
	CPU413-2 DP CPU414-1 CPU414-2 DP CPU414-3 DP CPU416-1 CPU416-2 DP CPU416-3 DP CPU417-4	CP441-2 + IF963-X27	RS422/485 (4wire)	Setting Example 4 (page 17)	Cable Diagram 2 (page 27)

NOTE

- Set the execution time of the logic functions in the Display to "100 ms" or less. If the longer time is set, an error may occur in the communication with the external device.

■ IPC COM Port

When connecting IPC with an External Device, the COM port used depends on the series and SIO type. Please refer to the IPC manual for details.

Usable port

Series	Usable Port		
	RS-232C	RS-422/485(4 wire)	RS-422/485(2 wire)
PS-2000B	COM1 ^{*1} , COM2, COM3 ^{*1} , COM4	-	-
PS-3450A, PS-3451A, PS3000-BA, PS3001-BD	COM1, COM2 ^{*1*2}	COM2 ^{*1*2}	COM2 ^{*1*2}
PS-3650A (T41 model), PS-3651A (T41 model)	COM1 ^{*1}	-	-
PS-3650A (T42 model), PS-3651A (T42 model)	COM1 ^{*1*2} , COM2	COM1 ^{*1*2}	COM1 ^{*1*2}
PS-3700A (Pentium®4-M) PS-3710A	COM1 ^{*1} , COM2 ^{*1} , COM3 ^{*2} , COM4	COM3 ^{*2}	COM3 ^{*2}
PS-3711A	COM1 ^{*1} , COM2 ^{*2}	COM2 ^{*2}	COM2 ^{*2}
PS4000 ^{*3}	COM1, COM2	-	-
PL3000	COM1 ^{*1*2} , COM2 ^{*1} , COM3, COM4	COM1 ^{*1*2}	COM1 ^{*1*2}
PE-4000B Atom N270	COM1, COM2	-	-
PE-4000B Atom N2600	COM1, COM2	COM3 ^{*4} , COM4 ^{*4} , COM5 ^{*4} , COM6 ^{*4}	COM3 ^{*4} , COM4 ^{*4} , COM5 ^{*4} , COM6 ^{*4}
PS5000 (Slim Panel Type Core i3 Model) ^{*5*6}	COM1, COM2 ^{*4}	COM2 ^{*4}	COM2 ^{*4}
PS5000 (Slim Panel Type Atom Model) ^{*5*6}	COM1, COM2 ^{*7}	COM2 ^{*7}	COM2 ^{*7}
PS5000 (Enclosed Panel Type) ^{*8}	COM1	-	-
PS5000 (Modular Type PFXPU/PFXPP) ^{*5*6} PS5000 (Modular Type PFXPL2B5-6)	COM1 ^{*7}	COM1 ^{*7}	COM1 ^{*7}
PS5000 (Modular Type PFXPL2B1-4)	COM1, COM2 ^{*7}	COM2 ^{*7}	COM2 ^{*7}
PS6000 (Advanced Box) PS6000 (Standard Box)	COM1 ^{*9}	*10	*10
PS6000 (Basic Box)	COM1 ^{*9}	COM1 ^{*9}	COM1 ^{*9}
PSA6000	COM1	COM2 ^{*4}	COM2 ^{*4}

*1 The RI/5V can be switched. Use the IPC's switch to change if necessary.

*2 Set up the SIO type with the DIP Switch. Please set up as follows according to SIO type to be used.

- *3 When making communication between an External Device and COM port on the Expansion slot, only RS-232C is supported. However, ER (DTR/CTS) control cannot be executed because of the specification of COM port.
For connection with External Device, use user-created cables and disable Pin Nos. 1, 4, 6 and 9. Please refer to the IPC manual for details of pin layout.
- *4 Set up the SIO type with the BIOS. Please refer to the IPC manual for details of BIOS.
- *5 When setting up communication between an External Device and the RS-232C/422/485 interface module, use the IPC (RS-232C) or PS5000 (RS-422/485) cable diagrams. However, when using PFXZPBMPR42P2 in a RS-422/485 (4-wire) configuration with no flow control, connect 7.RTS+ and 8.CTS+, and connect 6.RTS- and 9.CTS-.
When using RS-422/485 communication with External Devices, you may need to reduce the transmission speed and increase the TX Wait time.
- *6 To use RS-422/485 communication on the RS-232C/422/485 interface module, the DIP Switch setting is required. Please refer to "Knowledge Base" (FAQs) on the support site. (<http://www.pro-face.com/trans/en/manual/1001.html>)

Settings	FAQ ID
PFXZPBMPR42P2, RS422/485 change method	FA263858
PFXZPBMPR42P2 termination resistor setting	FA263974
PFXZPBMPR44P2, RS422/485 change method	FA264087
PFXZPBMPR44P2 termination resistor setting	FA264088

- *7 Set up the SIO type with the DIP Switch. Please refer to the IPC manual for details of DIP Switch. The BOX Atom has not a switch to set the RS-232C, RS-422/485 mode. Use the BIOS for the setting.
- *8 For the connection with the External Device, on the user-created cable read as if the connector on the Display-side is a M12 A-coding 8 pin socket. The pin assignment is the same as described in the cable diagram. For the M12 A-coding connector, use PFXZPSCNM122.
- *9 In addition to COM1, you can also use the COM port on the optional interface.
- *10 Install the optional interface in the expansion slot.

DIP Switch settings (PL3000 / PS3000 Series)

RS-232C

DIP Switch	Setting	Description
1	OFF*1	Reserved (always OFF)
2	OFF	SIO type: RS-232C
3	OFF	
4	OFF	Output mode of SD (TXD) data: Always output
5	OFF	Terminal resistance (220Ω) insertion to SD (TXD): None
6	OFF	Terminal resistance (220Ω) insertion to RD (RXD): None
7	OFF	Short-circuit of SDA (TXA) and RDA (RXA): Not available
8	OFF	Short-circuit of SDB (TXB) and RDB (RXB): Not available
9	OFF	RS (RTS) Auto control mode: Disabled
10	OFF	

*1 When using PS-3450A, PS-3451A, PS3000-BA and PS3001-BD, turn ON the set value.

RS-422/485 (4 wire)

DIP Switch	Setting	Description
1	OFF	Reserved (always OFF)
2	ON	SIO type: RS-422/485
3	ON	
4	OFF	Output mode of SD (TXD) data: Always output
5	OFF	Terminal resistance (220Ω) insertion to SD (TXD): None
6	OFF	Terminal resistance (220Ω) insertion to RD (RXD): None
7	OFF	Short-circuit of SDA (TXA) and RDA (RXA): Not available
8	OFF	Short-circuit of SDB (TXB) and RDB (RXB): Not available
9	OFF	RS (RTS) Auto control mode: Disabled
10	OFF	

RS-422/485 (2 wire)

DIP Switch	Setting	Description
1	OFF	Reserved (always OFF)
2	ON	SIO type: RS-422/485
3	ON	
4	OFF	Output mode of SD (TXD) data: Always output
5	OFF	Terminal resistance (220Ω) insertion to SD (TXD): None
6	OFF	Terminal resistance (220Ω) insertion to RD (RXD): None
7	ON	Short-circuit of SDA (TXA) and RDA (RXA): Available
8	ON	Short-circuit of SDB (TXB) and RDB (RXB): Available
9	ON	RS (RTS) Auto control mode: Enabled
10	ON	

2 Selection of External Device

Select the External Device to be connected to the Display.

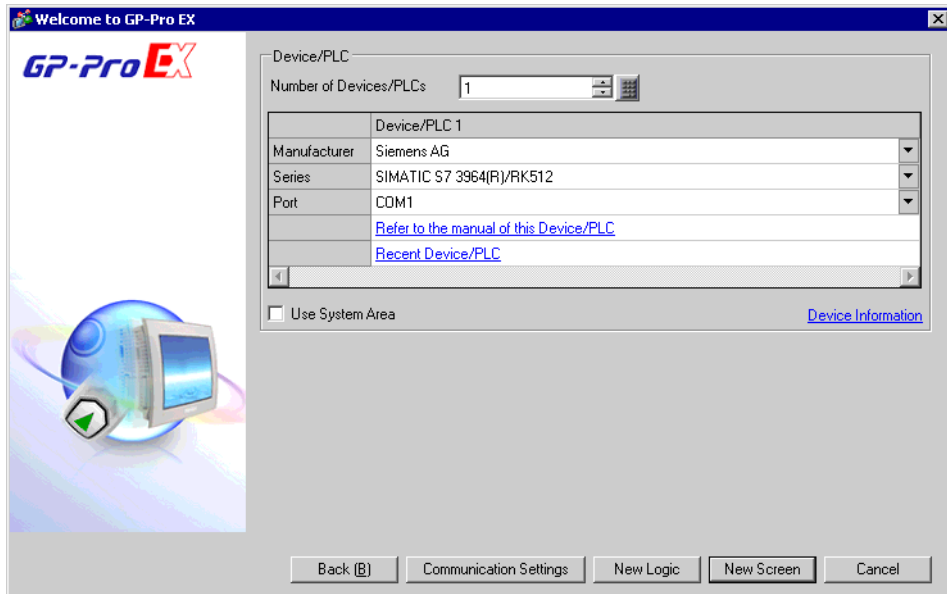

Setup Items	Setup Description
Number of Devices/PLCs	Enter an integer from 1 to 4 to define the number of Devices/PLCs to connect to the display.
Manufacturer	Select the manufacturer of the External Device to connect. Select "Siemens AG".
Series	Select the External Device model (series) and the connection method. Select "SIMATIC S7 3964(R)/RK512". In System configuration, make sure the External Device you are connecting is supported by "SIMATIC S7 3964(R)/RK512". ☞ "1 System Configuration" (page 3)
Port	Select the Display port to connect to the External Device.
Use System Area	Check this option to synchronize the system data area of the Display and the device (memory) of the External Device. When synchronized, you can use the External Device's ladder program to switch the display or display the window on the Display. Cf. GP-Pro EX Reference Manual "LS Area (Direct Access Method Area)" This feature can also be set in GP-Pro EX or in the Display's offline mode. Cf. GP-Pro EX Reference Manual "System Settings [Display Unit] - [System Area] Settings Guide" Cf. Maintenance/Troubleshooting Guide "Main Unit - System Area Settings"

3 Example of Communication Setting

Examples of communication settings of the Display and the External Device, recommended by Pro-face, are shown.

3.1 Setting Example 1

■ Setting of GP-Pro EX

◆ Communication Settings

To display the setup screen, from the [Project] menu, point to [System Settings] and select [Device/PLC].

Device/PLC 1

Summary [Change Device/PLC](#)

Manufacturer: Siemens AG Series: SIMATIC S7 3964(R)/RK512 Port: COM1

Text Data Mode: 1 [Change](#)

Communication Settings

SID Type: RS232C RS422/485(2wire) RS422/485(4wire)

Speed: 9600

Data Length: 7 8

Parity: NONE EVEN ODD

Stop Bit: 1 2

Flow Control: NONE ER(DTR/CTS) XON/XOFF

Timeout: 3 (sec)

Retry: 2

Wait To Send: 0 (ms)

RI / VCC: RI VCC

In the case of RS232C, you can select the 9th pin to RI (Input) or VCC (5V Power Supply). If you use the Digital's RS232C Isolation Unit, please select it to VCC.

Default

Device-Specific Settings

Allowable Number of Devices/PLCs: 1 [Add Device](#)

No.	Device Name	Settings
1	PLC1	Block Check (BCC)=ON, Device Names=English (I/Q/M/T/Z/DB)

[Add Indirect Device](#)

IMPORTANT

- When using GP6000 Series, "Wait to Send" must be set to 2 ms or longer. If this value is not set correctly, error messages such as "receive data error" may appear during operation and normal communication may not be possible.

◆ Device Setting

To display the [Individual Device Settings] dialog box, from [Device-Specific Settings] in the [Device/PLC] window, select the external device and click [Settings] .

Individual Device Settings

PLC1

Block Check (BCC)

Device Names: English (I/Q/M/T/Z/DB) German (E/A/M/T/Z/DB)

Default

OK [O] Cancel

■ Settings of External Device

- (1) Startup "SIMATIC Manager" and create the new project. Set the optional project name and click [OK]. New project is created.
- (2) From the menu bar, select [Insert], [Station], [Name of CPU type to use] (ex: [1 SIMATIC 400 Station]) in this order.
- (3) [(Name of CPU type to use)] (ex: [SIMATIC 400 (1)]) is created in the project. Double-click [Hardware] of the name of CPU type to use.
- (4) When the [HW Config] screen displayed, open [(Name of CPU type to use)], [(RACK type to use)] (ex: [SIMATIC 400], [RACK-400]) in this order from the left tree and select the base unit of the using model.
- (5) Drag & drop the selected base unit to the upper right window. The rack figure is created in the window.
- (6) Drag & drop the using power unit in the rack.
- (7) Similarly, drag & drop the using CPU unit.
- (8) When using CPUxxx-xDP, the [Properties - PROFIBUS interface DP] dialog box is displayed. In that case, click [Cancel] and close the dialog box.
- (9) Similarly, drag & drop the using link unit.
- (10) Double-click the CPU unit dropped in the rack.
- (11) When the [MPI port] setting dialog box is displayed, click [Properties].
- (12) Click [Properties] as "MPI(1) 187.5 Kbps" is selected as default. The value entered in [Address] this time becomes the Destination Node No. (PLC Address) you set in GP-Pro EX. The default is "2".
- (13) To change the speed [Transmission rate] and the highest value of the node No. [Highest MPI address], click the [Network Settings] tab.
Select [187.5Kbps] for [Transmission rate]. To change the highest value of the node No. (Highest MPI address), check [Change] to allow you to select from the list.
- (14) When you finish setting, click [OK] and close the dialog box.
- (15) Close other dialog boxes similarly.

(16) Select [(Name of CPU type to use)] in the project, and open [Blocks] in the program, then double-click [OB1].

(17) Here, you need to arrange the ladder program. Sample ladder program is shown below.

```

CALL "P_RCV_RK" , DB7
EN_R   :=TRUE
R      :=FALSE
LADDR :=256
DB_NO  :=
DDB_NO :=
L_TYP  :=
L_NO   :=
L_OFFSET:=
L_CF_BYT:=
L_CF_BIT:=
MDR    :=
ERROR  :=
LEN    :=
STATUS :=

```

(18) Next, double-click [Hardware] in the CPU.

(19) Double-click the link unit as the link unit to use is already registered by the previous operation.

(20) To enable the communication between the External Device and the Display, click the [Parameter] button.

(21) The Parameter window is displayed. Select [RK512] from the [Protocol] list box and double-click the [Protocol] image in the window.

(22) When the [Protocol] dialog box is displayed, set in the [RK 512] tab as below.

Setup Items	Setup Description
With Block Check	Check
Use Default Values	Check
Transmission Rate	9600 bps
Stop Bits	1
Parity	Even
Priority	Low

(23) When you finish setting, click [OK] and close the dialog box.

3.2 Setting Example 2

■ Setting of GP-Pro EX

◆ Communication Settings

To display the setup screen, from the [Project] menu, point to [System Settings] and select [Device/PLC].

IMPORTANT

- When using GP6000 Series, "Wait to Send" must be set to 2 ms or longer. If this value is not set correctly, error messages such as "receive data error" may appear during operation and normal communication may not be possible.

◆ Device Setting

To display the [Individual Device Settings] dialog box, from [Device-Specific Settings] in the [Device/PLC] window, select the external device and click [Settings] .

■ Settings of External Device

- (1) Startup "SIMATIC Manager" and create the new project. Set the optional project name and click [OK]. New project is created.
- (2) From the menu bar, select [Insert], [Station], [(Name of CPU type to use)] in this order.
- (3) [(Name of CPU type to use)] is created in the project. Double-click [Hardware] of the name of CPU type to use.
- (4) When the [HW Config] screen displayed, open [(Name of CPU type to use)], [(RACK type to use)] in this order from the left tree and select the base unit of the using model.
- (5) Drag & drop the selected base unit to the upper right window. The rack figure is created in the window.
- (6) Drag & drop the using power unit in the rack.
- (7) Similarly, drag & drop the using CPU unit.
- (8) When using CPUxxx-xDP, the [Properties - PROFIBUS interface DP] dialog box is displayed. In that case, click [Cancel] and close the dialog box.
- (9) Similarly, drag & drop the using link unit.
- (10) Double-click the CPU unit dropped in the rack.
- (11) When the [MPI port] setting dialog box is displayed, click [Properties].
- (12) Click [Properties] as "MPI(1) 187.5 Kbps" is selected as default. The value entered in [Address] this time becomes the Destination Node No. (PLC Address) you set in GP-Pro EX. The default is "2".
- (13) To change the speed [Transmission rate] and the highest value of the node No. [Highest MPI address], click the [Network Settings] tab.
Select [187.5Kbps] for [Transmission rate]. To change the highest value of the node No. (Highest MPI address), check [Change] to allow you to select from the list.
- (14) When you finish setting, click [OK] and close the dialog box.
- (15) Close other dialog boxes similarly.

(16) Select [(Name of CPU type to use)] in the project, and open [Blocks] in the program, then double-click [OB1].

(17) Here, you need to arrange the ladder program. Sample ladder program is shown below.

```

CALL "P_RCV_RK" , DB7
EN_R   :=TRUE
R      :=FALSE
LADDR  :=256
DB_NO  :=
DBB_NO :=
L_TYP  :=
L_NO   :=
L_OFFSET:=
L_CF_BYT:=
L_CF_BIT:=
MDR    :=
ERROR  :=
LEN    :=
STATUS :=

```

(18) Next, double-click [Hardware] in the CPU.

(19) Double-click the link unit as the link unit to use is already registered by the previous operation.

(20) To enable the communication between the External Device and the Display, click the [Parameter] button.

(21) The Parameter window is displayed. Select [RK512] from the [Protocol] list box and double-click the [Protocol] image in the window.

(22) When the [Protocol] dialog box is displayed, set in the [RK 512] tab as below.

Setup Items	Setup Description
With Block Check	Check
Use Default Values	Check
Transmission Rate	9600 bps
Stop Bits	1
Parity	Even
Priority	Low

(23) When connecting CP341/CP441 with RS422/485, double-click the [Interface] tab and select [None] in [Initial State of the Receive Line].

(24) When you finish setting, click [OK] and close the dialog box.

3.3 Setting Example 3

■ Setting of GP-Pro EX

◆ Communication Settings

To display the setup screen, from the [Project] menu, point to [System Settings] and select [Device/PLC].

Device/PLC 1

Summary [Change Device/PLC](#)

Manufacturer: Siemens AG Series: SIMATIC S7 3964(R)/RK512 Port: COM1

Text Data Mode: 1 [Change](#)

Communication Settings

RS232C RS422/485(2wire) RS422/485(4wire)
 Speed: 9600
 Data Length: 7 8
 Parity: NONE EVEN ODD
 Stop Bit: 1 2
 Flow Control: NONE ER(DTR/CTS) XON/XOFF
 Timeout: 3 (sec)
 Retry: 2
 Wait To Send: 0 (ms)

RI VCC
 In the case of RS232C, you can select the 9th pin to RI (Input) or VCC (5V Power Supply). If you use the Digital's RS232C Isolation Unit, please select it to VCC.

Default

Device-Specific Settings

Allowable Number of Devices/PLCs: 1 [Add Device](#)

No.	Device Name	Settings	Add Indirect Device
1	PLC1	Block Check (BCC)=ON, Device Names=English (I/Q/T)	+

IMPORTANT

- When using GP6000 Series, "Wait to Send" must be set to 2 ms or longer. If this value is not set correctly, error messages such as "receive data error" may appear during operation and normal communication may not be possible.

◆ Device Setting

To display the [Individual Device Settings] dialog box, from [Device-Specific Settings] in the [Device/PLC] window, select the external device and click [Settings] .

Individual Device Settings

PLC1

Block Check (BCC)

Device Names: English (I/Q/M/T/C/DB) German (E/A/M/T/Z/DB)

Default

OK [O] Cancel

■ Settings of External Device

Use the ladder software (SIMATIC Manager STEP 7 S7/M7/C7) for communication settings of the External Device.

Refer to your External Device manual for details.

- (1) Start up the ladder software and create a new project.
- (2) Set the hardware. Double-click [Hardware] from the [(Name of CPU type to use)] of the created project tree view to display the [HW Config] window.
- (3) Register the unit to be used.
- (4) Double-click the Point-to-Point module to be used in the rack to display [Properties] dialog box.
- (5) Select the slot number to be used from the [Interface] of the [Basic Parameters] tab.
- (6) In the same way, select a module to be used from the [Module].
- (7) Click the [Parameter] to display the [Assigning Parameters to Point-To-Point Connections] window.

NOTE

- The [Parameter] is enabled after setting up the Protocol on the Point-to-Point module's attached disk.

- (8) Select [RK512] from the [Protocol].
- (9) Double-click the mail icon to display [Protocol] dialog box.
- (10) Set the setting items with [RK512] tab as follows.

Setup Items	Setup Description
With Block Check	Check
Use Default Values	Check
Transmission Rate	9600 bps
Stop Bits	1
Parity	Even
Priority	Low

- (11) Click [OK].
- (12) Save the setting and close the window.
- (13) Connect the module to be used for Point-to-Point network with the [General] tab.
- (14) Close the [HW Config] window.
- (15) Set a block. Select [Open] from the [File] menu to display the [Open Project] dialog box.
- (16) Select "zXX21_03_PtP_Com_CP441" from the [Sample projects] tab.
- (17) Click [OK].
- (18) Select "CP441 RK512 Send/Recv" from the sample project tree view.
- (19) Overwrite "S7 Program (1)" of created project with [Symbols] of "CP441 RK512 Send/Recv".

- (20) In the same way, overwrite [Blocks] of the project created except for [System Data] from the [Blocks].
- (21) Double-click [OB1] from the [Blocks] of created project tree view to display the [LAD/STL/FBD] window.
- (22) Delete the line of "UC"SEND"/Call of FC for execution BSEND-Jobs" of Network 1.
- (23) Save the setting and close the window.
- (24) Set Network Configuration. Select [(CPU name in use)] from the created project.
- (25) Double-click [Connections] in the project window to start up NetPro.
- (26) Right-click the CPU to be used from the created project on NetPro.
- (27) Select [Insert New Connection] to display the [Insert New Connection] dialog box.
- (28) Select [Unspecified] from the created project of [Connection Partner] tree view.
- (29) Select [Point-to-point connection] from the [Type] of [Connection].
- (30) Click [OK] to display the [Properties -PtP connection] dialog box.
- (31) Click [OK].
- (32) Confirm that Point-to-Point connection is displayed in the [Local ID] as "1000".
- (33) Select [Exit] from the [Network] menu to close the window.
- (34) Download the hardware setting and Blocks setting to the Extended Device.
- (35) Download the network configuration setting to the Extended Device.

3.4 Setting Example 4

■ Setting of GP-Pro EX

◆ Communication Settings

To display the setup screen, from the [Project] menu, point to [System Settings] and select [Device/PLC].

The screenshot shows the 'Device/PLC 1' configuration window. The 'Summary' section includes:

- Manufacturer: Siemens AG
- Series: SIMATIC S7 3964(R)/RK512
- Port: COM1
- Text Data Mode: 1 (Change)

 The 'Communication Settings' section includes:

- SIQ Type: RS232C, RS422/485(2wire), RS422/485(4wire)
- Speed: 9600
- Data Length: 7, 8
- Parity: NONE, EVEN, ODD
- Stop Bit: 1, 2
- Flow Control: NONE, ER(DTR/CTS), XON/XOFF
- Timeout: 3 (sec)
- Retry: 2
- Wait To Send: 0 (ms)

 Below these settings is a section for 'RI / VCC' with radio buttons for 'RI' and 'VCC'. A note states: 'In the case of RS232C, you can select the 9th pin to RI (Input) or VCC (5V Power Supply). If you use the Digital's RS232C Isolation Unit, please select it to VCC.' A 'Default' button is also present.

 The 'Device-Specific Settings' section shows:

- Allowable Number of Devices/PLCs: 1 (Add Device)
- Table with columns: No., Device Name, Settings. Row 1: 1, PLC1, Block Check (BCC)=ON, Device Names=English (I/Q/T)
- Buttons: Add Indirect Device, Default

IMPORTANT

- When using GP6000 Series, "Wait to Send" must be set to 2 ms or longer. If this value is not set correctly, error messages such as "receive data error" may appear during operation and normal communication may not be possible.

◆ Device Setting

To display the [Individual Device Settings] dialog box, from [Device-Specific Settings] in the [Device/PLC] window, select the external device and click [Settings] .

The 'Individual Device Settings' dialog box for 'PLC1' shows:

- Block Check (BCC)
- Device Names: English (I/Q/M/T/C/DB), German (E/A/M/T/Z/DB)
- Buttons: Default, OK (O), Cancel

■ Settings of External Device

Use the ladder software (SIMATIC Manager STEP 7 S7/M7/C7) for communication settings of the External Device.

Refer to your External Device manual for details.

- (1) Start up the ladder software and create a new project.
- (2) Set the hardware. Double-click [Hardware] from the [(Name of CPU type to use)] of the created project tree view to display the [HW Config] window.
- (3) Register the unit to be used.
- (4) Double-click the Point-to-Point module to be used in the rack to display [Properties] dialog box.
- (5) Select the slot number to be used from the [Interface] of the [Basic Parameters] tab.
- (6) In the same way, select a module to be used from the [Module].
- (7) Click the [Parameter] to display the [Assigning Parameters to Point-To-Point Connections] window.

NOTE

- The [Parameter] is enabled after setting up the Protocol on the Point-to-Point module's attached disk.

- (8) Select [RK512] from the [Protocol].
- (9) Double-click the mail icon to display [Protocol] dialog box.
- (10) Set the setting items with [RK512] tab as follows.

Setup Items	Setup Description
With Block Check	Check
Use Default Values	Check
Transmission Rate	9600 bps
Stop Bits	1
Parity	Even
Priority	Low

- (11) Click [OK].
- (12) Save the setting and close the window.
- (13) Connect the module to be used for Point-to-Point network with the [General] tab.
- (14) Close the [HW Config] window.
- (15) Set a block. Select [Open] from the [File] menu to display the [Open Project] dialog box.
- (16) Select "zXX21_03_PtP_Com_CP441" from the [Sample projects] tab.
- (17) Click [OK].
- (18) Select "CP441 RK512 Send/Recv" from the sample project tree view.
- (19) Overwrite "S7 Program (1)" of created project with [Symbols] of "CP441 RK512 Send/Recv".

- (20) In the same way, overwrite [Blocks] of the project created except for [System Data] from the [Blocks].
- (21) Double-click [OB1] from the [Blocks] of created project tree view to display the [LAD/STL/FBD] window.
- (22) Delete the line of "UC"SEND"/Call of FC for execution BSEND-Jobs" of Network 1.
- (23) Save the setting and close the window.
- (24) Set Network Configuration. Select [(CPU name in use)] from the created project.
- (25) Double-click [Connections] in the project window to start up NetPro.
- (26) Right-click the CPU to be used from the created project on NetPro.
- (27) Select [Insert New Connection] to display the [Insert New Connection] dialog box.
- (28) Select [Unspecified] from the created project of [Connection Partner] tree view.
- (29) Select [Point-to-point connection] from the [Type] of [Connection].
- (30) Click [OK] to display the [Properties -PtP connection] dialog box.
- (31) Click [OK].
- (32) Confirm that Point-to-Point connection is displayed in the [Local ID] as "1000".
- (33) Select [Exit] from the [Network] menu to close the window.
- (34) Download the hardware setting and Blocks setting to the Extended Device.
- (35) Download the network configuration setting to the Extended Device.

4 Setup Items

Set communication settings of the Display with GP-Pro EX or in offline mode of the Display.

The setting of each parameter must be identical to that of External Device.

 "3 Example of Communication Setting" (page 8)

4.1 Setup Items in GP-Pro EX

■ Communication Settings

To display the setup screen, from the [Project] menu, point to [System Settings] and select [Device/PLC].

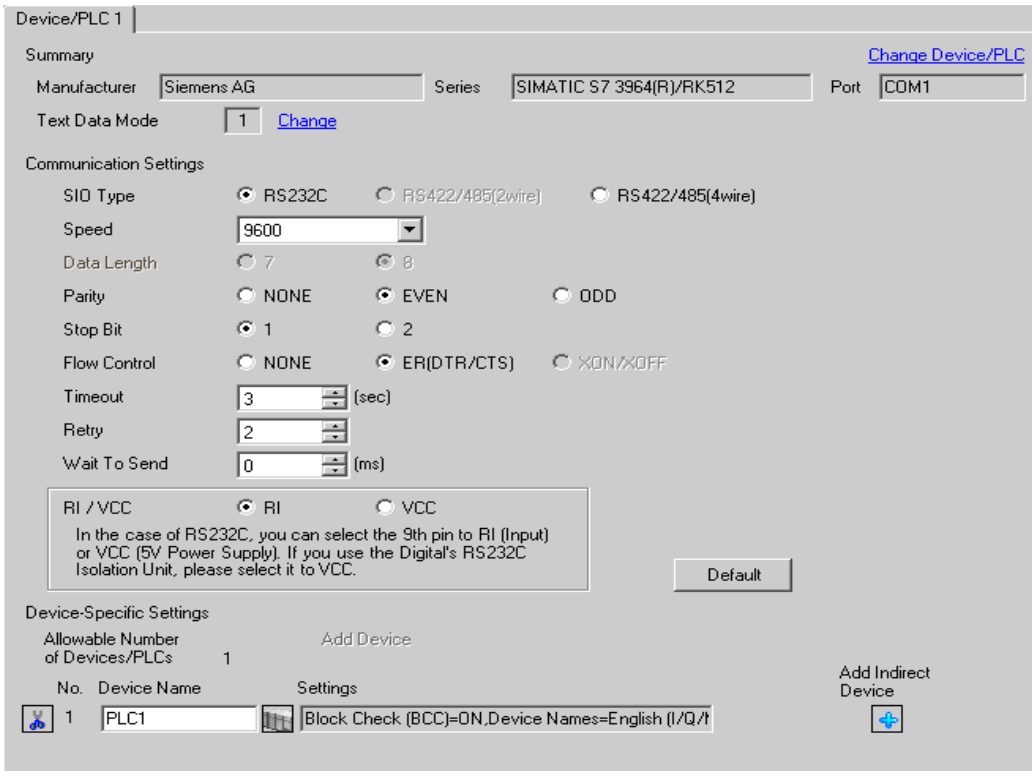

Device/PLC 1

Summary [Change Device/PLC](#)

Manufacturer: Siemens AG Series: SIMATIC S7 3964(R)/RK512 Port: COM1

Text Data Mode: 1 [Change](#)

Communication Settings

SIO Type: RS232C RS422/485(2wire) RS422/485(4wire)

Speed: 9600

Data Length: 7 8

Parity: NONE EVEN ODD

Stop Bit: 1 2

Flow Control: NONE ER(DTR/CTS) XON/XOFF

Timeout: 3 (sec)

Retry: 2

Wait To Send: 0 (ms)

RI / VCC: RI VCC

In the case of RS232C, you can select the 9th pin to RI (Input) or VCC (5V Power Supply). If you use the Digital's RS232C Isolation Unit, please select it to VCC.

Default

Device-Specific Settings

Allowable Number of Devices/PLCs: 1 [Add Device](#)

No.	Device Name	Settings
1	PLC1	Block Check (BCC)=ON, Device Names=English (I/Q/T)

[Add Indirect Device](#)

Setup Items	Setup Description
SIO Type	Select the SIO type to communicate with the External Device.
Speed	Select speed between the External Device and the Display.
Data Length	Select data length.
Parity	Select how to check parity.
Stop Bit	Select stop bit length.
Flow Control	Select the communication control method to prevent overflow of transmission and reception data.
Timeout	Use an integer from 1 to 127 to enter the time (s) for which the Display waits for the response from the External Device.

continued to next page

Setup Items	Setup Description
Retry	In case of no response from the External Device, use an integer from 0 to 255 to enter how many times the Display retransmits the command.
Wait To Send	Use an integer from 0 to 255 to enter standby time (ms) for the Display from receiving packets to transmitting next commands. IMPORTANT <ul style="list-style-type: none"> When using GP6000 Series, "Wait to Send" must be set to 2 ms or longer. If this value is not set correctly, error messages such as "receive data error" may appear during operation and normal communication may not be possible.
RI/VCC	Switch the 9th pin setting when you select RS232C for SIO type. It is necessary to change RI/5V by changeover switch of IPC when connect with IPC. Please refer to the manual of the IPC for more detail.

NOTE • Refer to the GP-Pro EX Reference Manual for Indirect Device.

Cf. GP-Pro EX Reference Manual "Changing the Device/PLC at Runtime (Indirect Device)"

■ Device Setting

To display the [Individual Device Settings] dialog box, from [Device-Specific Settings] in the [Device/PLC] window, select the external device and click [Settings] .

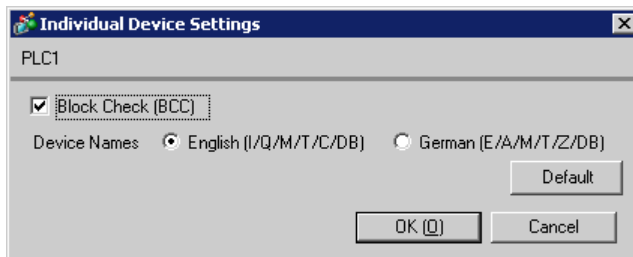

Setup Items	Setup Description
Block Check (BCC)	Check to enable the check sum.
Device Names	Select whether the device name is described in English (I/Q/M/T/C/DB) or German (E/A/M/T/Z/DB).

4.2 Setup Items in Offline Mode

NOTE

- Refer to the Maintenance/Troubleshooting guide for information on how to enter offline mode or about the operation.

Cf. Maintenance/Troubleshooting Guide "Offline Mode"

- The number of the setup items to be displayed for 1 page in the offline mode depends on the Display in use. Please refer to the Reference manual for details.

■ Communication Settings

To display the setting screen, touch [Device/PLC Settings] from [Peripheral Settings] in the offline mode. Touch the External Device you want to set from the displayed list, and touch [Communication Settings].

Comm.	Device	Option		
SIMATIC S7 3964(R)/RK512		[COM1]		Page 1/1
SIO Type		RS232C		
Speed		9600		
Data Length		8		
Parity		<input type="radio"/> NONE <input checked="" type="radio"/> EVEN <input type="radio"/> ODD		
Stop Bit		<input checked="" type="radio"/> 1 <input type="radio"/> 2		
Flow Control		ER(DTR/CTS)		
Timeout(s)		3	▼ ▲	
Retry		2	▼ ▲	
Wait To Send(ms)		0	▼ ▲	
	Exit		Back	2005/09/02 13:03:26

Setup Items	Setup Description
SIO Type	Select the SIO type to communicate with the External Device. IMPORTANT To make the communication settings correctly, confirm the serial interface specifications of Display unit for [SIO Type]. We cannot guarantee the operation if a communication type that the serial interface does not support is specified. For details concerning the serial interface specifications, refer to the manual for Display unit.
Speed	Select speed between the External Device and the Display.
Data Length	Select data length.
Parity	Select how to check parity.
Stop Bit	Select stop bit length.
Flow Control	Select the communication control method to prevent overflow of transmission and reception data.
Timeout	Use an integer from 1 to 127 to enter the time (s) for which the Display waits for the response from the External Device.

Setup Items	Setup Description
Retry	In case of no response from the External Device, use an integer from 0 to 255 to enter how many times the Display retransmits the command.
Wait To Send	Use an integer from 0 to 255 to enter standby time (ms) for the Display from receiving packets to transmitting next commands. <div style="border: 1px solid black; padding: 2px; display: inline-block; margin: 5px 0;">IMPORTANT</div> <ul style="list-style-type: none"> When using GP6000 Series, "Wait to Send" must be set to 2 ms or longer. If this value is not set correctly, error messages such as "receive data error" may appear during operation and normal communication may not be possible.

■ Device Setting

To display the setting screen, touch [Device/PLC Settings] from [Peripheral Settings]. Touch the External Device you want to set from the displayed list, and touch [Device Settings].

Comm.	Device	Option		
SIMATIC S7 3964(R)/RK512		[COM1]	Page 1/1	
Device/PLC Name		[PLC1]		
Block Check (BCC)		[Enable]		
Exit		Back		2005/09/02 13:03:28

Setup Items	Setup Description
Device/PLC Name	Select the External Device for device setting. Device name is a title of External Device set with GP-Pro EX.(Initial value [PLC1])
Block Check (BCC)	Select [Enable] to enable the check sum.

■ Option

To display the setting screen, touch [Device/PLC Settings] from [Peripheral Settings]. Touch the External Device you want to set from the displayed list, and touch [Option].

Comm.	Device	Option		
SIMATIC S7 3964(R)/RK512		[COM1]	Page 1/1	
RI / VCC <input checked="" type="radio"/> RI <input type="radio"/> VCC In the case of RS232C, you can select the 9th pin to RI (Input) or VCC (5V Power Supply). If you use the Digital's RS232C Isolation Unit, please select it to VCC.				
Exit		Back		2005/09/02 13:03:31

Setup Items	Setup Description
RI/VCC	You can switch RI/VCC of the 9th pin when you select RS232C for SIO type. It is necessary to change RI/5V by changeover switch of IPC when connect with IPC. Please refer to the manual of the IPC for more detail.

NOTE

- GP-4100 series, GP-4*01TM, GP-Rear Module, LT-4*01TM and LT-Rear Module do not have the [Option] setting in the offline mode.

5 Cable Diagram

The cable diagram shown below may be different from the cable diagram recommended by Siemens AG. Please be assured there is no operational problem in applying the cable diagram shown in this manual.

- The FG pin of the main body of the External Device must be D-class grounded. Please refer to the manual of the External Device for more details.
- SG and FG are connected inside the Display. When connecting SG to the External Device, design the system not to form short-circuit loop.
- Connect the isolation unit, when communication is not stabilized under the influence of a noise etc..

Cable Diagram 1

Display (Connection Port)	Cable		Remarks
GP3000 (COM1) GP4000 ^{*1} (COM1) GP6000 (COM1) SP5000 ^{*2} (COM1/2) SP-5B00 (COM1) ST3000 (COM1) ST6000 (COM1) STM6000 (COM1) STC6000 (COM1) ET6000 (COM1) LT3000 (COM1) IPC ^{*3} PC/AT	1A	User-created cable	The cable length must be 15m or less.
GP-4105 (COM1) GP-4115T (COM1) GP-4115T3 (COM1)	1B	User-created cable	The cable length must be 15m or less.
LT-4*01TM (COM1) LT-Rear Module (COM1)	1C	RJ45 RS-232C Cable (5m) by Pro-face PFXZLMCBJR21	The cable length must be 5m or less.

*1 All GP4000 models except GP-4100 Series and GP-4203T

*2 Except SP-5B00

*3 Only the COM port which can communicate by RS-232C can be used.

 ■ IPC COM Port (page 4)

1A)

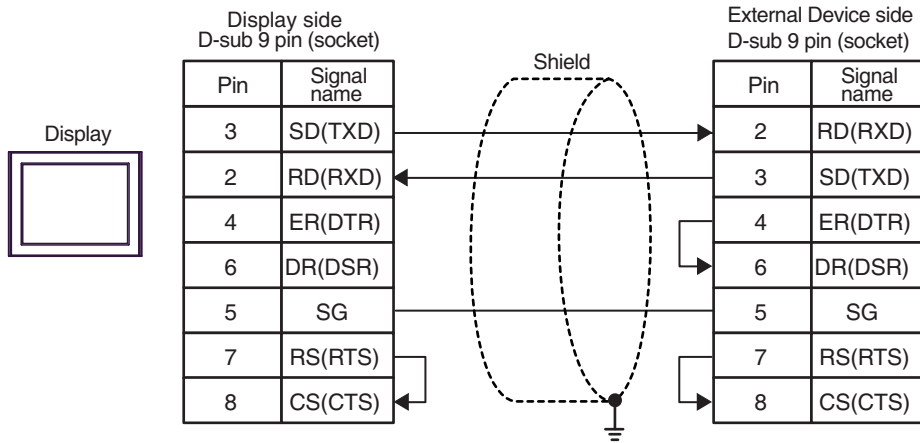

1B)

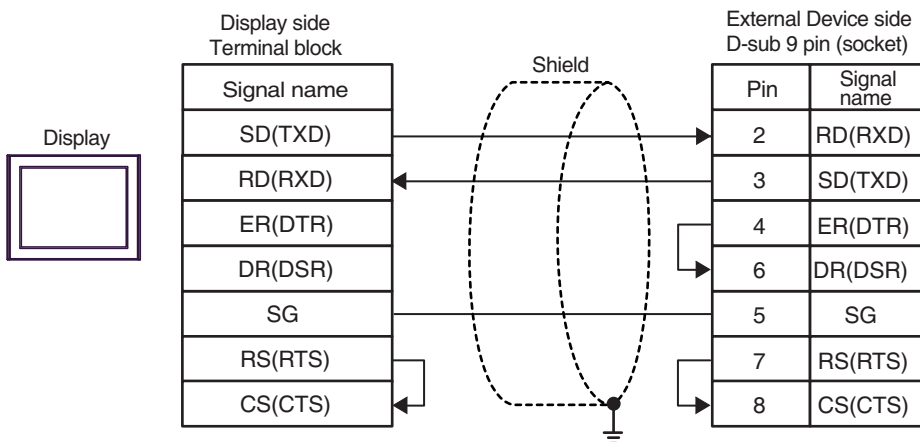

1C)

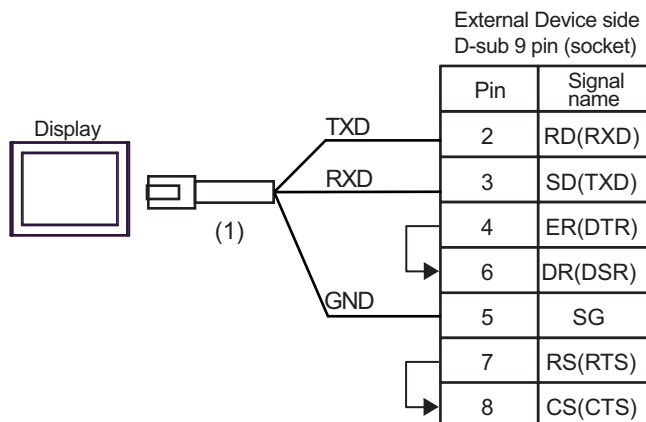

Legend	Name	Notes
(1)	RJ45 RS-232C Cable (5m) by Pro-face PFXZLMCBJR21	

Cable Diagram 2

Display (Connection Port)	Cable		Remarks
GP3000* ¹ (COM1) AGP-3302B (COM2) GP4000* ² (COM2) GP-4201T (COM1) GP6000 (COM2) GP-4*01TM (COM1) GP-Rear Module (COM1) SP5000* ³ (COM1/2) SP-5B00 (COM2) ST3000* ⁴ (COM2) ST6000* ⁵ (COM2) ST-6200 (COM1) STM6000 (COM1) STC6000 (COM1) ET6000* ⁶ (COM2) LT3000 (COM1) IPC* ⁷ PS6000 (Basic Box) (COM1/2)	2A	User-created cable	Arrange the cable length as below according to the speed. 19200 or less: 1000m or less 38400 : 500m or less 115200 : 200m or less
GP3000* ⁸ (COM2)	2B	Online adapter by Pro-face CA4-ADPONL-01 + User-created cable	Arrange the cable length as below according to the speed. 19200 or less: 1000m or less 38400 : 500m or less 115200 : 200m or less
GP-4106 (COM1) GP-4116T (COM1)	2C	User-created cable	Arrange the cable length as below according to the speed. 19200 or less: 1000m or less 38400 : 500m or less 115200 : 200m or less
PE-4000B* ⁹ PS5000* ⁹ PS6000 (Optional Interface)* ⁹ PSA6000* ⁹	2D	User-created cable	Arrange the cable length as below according to the speed. 19200 or less: 1000m or less 38400 : 500m or less 115200 : 200m or less

*1 All GP3000 models except AGP-3302B

*2 All GP4000 models except GP-4100 series, GP-4*01TM, GP-Rear Module, GP-4201T and GP-4*03T

*3 Except SP-5B00

*4 Except AST-3211A and AST-3302B

*5 Except ST-6200

*6 Due to the COM port specifications, flow control is not possible. Omit wiring the control pins on the Display side of the cable diagram.

*7 Only the COM port which can communicate by RS-422/485 (4 wire) can be used. (Except PE-4000B, PS5000, PS6000 and PSA6000)

 ■ IPC COM Port (page 4)

*8 All GP3000 models except GP-3200 series and AGP-3302B

*9 Only the COM port which can communicate by RS-422/485 (4 wire) can be used.

☞ ■ IPC COM Port (page 4)

2A)

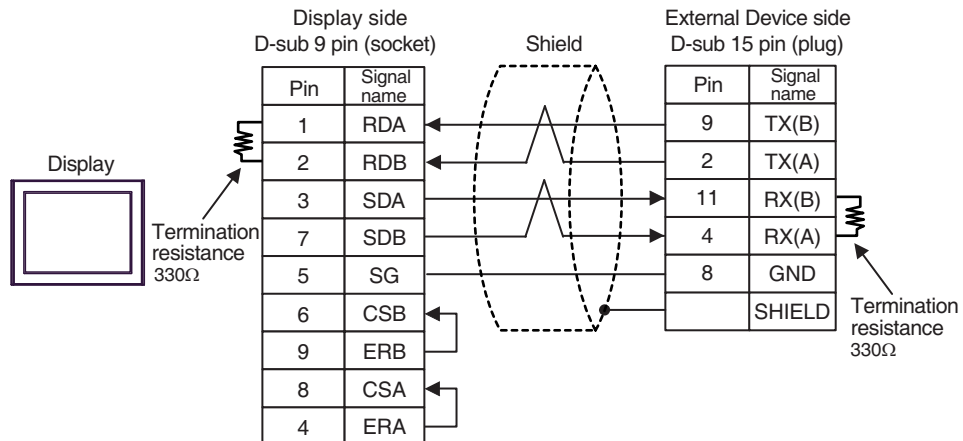

NOTE • We recommend that the termination resistance should be attached when using the cable in 50m or more length.

2B)

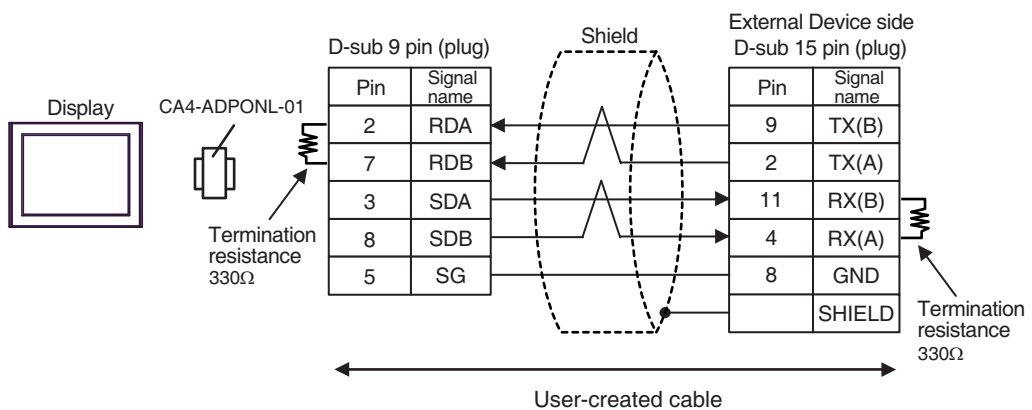

NOTE • We recommend that the termination resistance should be attached when using the cable in 50m or more length.

2C)

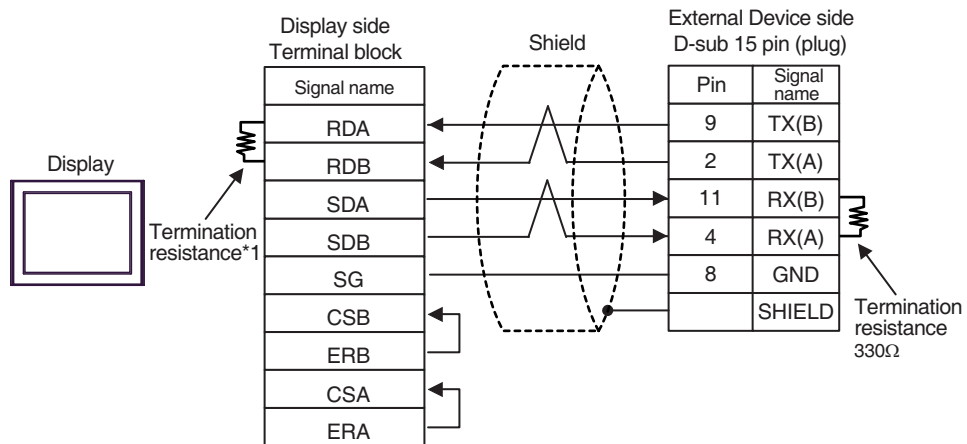

NOTE • We recommend that the termination resistance should be attached when using the cable in 50m or more length.

*1 The resistance in the Display is used as the termination resistance. Set the value of the DIP Switch on the rear of the Display as shown in the table below.

DIP Switch No.	Set Value
1	OFF
2	OFF
3	ON
4	OFF

2D)

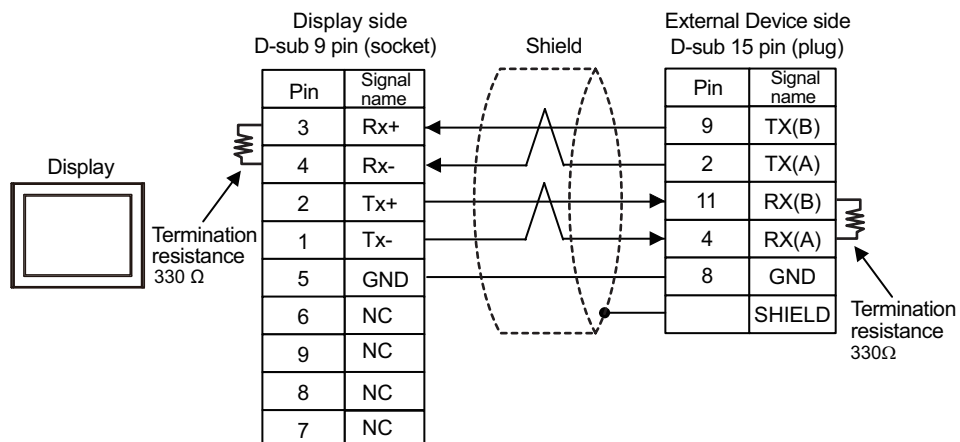





NOTE • We recommend that the termination resistance should be attached when using the cable in 50m or more length.

6 Supported Device

Range of supported device address is shown in the table below. Please note that the actually supported range of the devices varies depending on the External Device to be used. Please check the actual range in the manual of your External Device.

 This address can be specified as system data area.

Device	Bit Address		Word Address		32 bits	Remarks
	English	German	English	German		
Data Block	DB001.DBX000.0 - DB255.DBX511.7		DB001.DBW000 - DB255.DBW510		H/L	 *1
Input	I000.0 - I127.7	E000.0-E127.7	IW000 - IW126	EW000-EW126		 *2
Output	Q000.0 - Q127.7	A000.0-A127.7	QW000 - QW126	AW000 - AW126		 *2
Internal Marker	M000.0 - M255.7		MW000 - MW254			 *2
Timer	-----		T000 - T255			*2
Counter	-----		C000 - C255	Z000 - Z255		*2

*1 When you write the bit address, the Display reads the word address corresponding to that of the External Device first. Change only the target bit address among the word data once read, and write the word data to the External Device.

Note that the correct data may not be written if you change the word address value in the ladder program while the Display reads the data of the External Device and writes it to the External Device.

*2 Write disable

NOTE

- Please refer to the GP-Pro EX Reference Manual for system data area.
Cf. GP-Pro EX Reference Manual "LS Area (Direct Access Method Area)"
- Please refer to the precautions on manual notation for icons in the table.

 "Manual Symbols and Terminology"

7 Device Code and Address Code

Use device code and address code when you select "Device Type & Address" for the address type in data displays.

Device	Word Address		Device Code (HEX)	Address Code
	English	German		
Data Block	DB	DB	0000	(Data Block No. x 0x10000) + Value of (word address divided by 2)
Input	I	E	0080	Value of word address divided by 2
Output	Q	A	0081	Value of word address divided by 2
Internal Marker	M	M	0082	Value of word address divided by 2
Timer	T	T	0060	Word Address
Counter	C	Z	0061	Word Address

8 Error Messages

Error messages are displayed on the Display screen as follows: "No.: Device Name: Error Message (Error Occurrence Area)". Each description is shown below.

Item	Description
No.	Error No.
Device Name	Name of the External Device where error occurs. Device name is a title of the External Device set with GP-Pro EX. (Initial value [PLC1])
Error Message	Displays messages related to the error which occurs.
Error Occurrence Area	<p>Displays IP address or device address of the External Device where error occurs, or error codes received from the External Device.</p> <p>NOTE</p> <ul style="list-style-type: none"> • IP address is displayed such as "IP address(Decimal): MAC address(Hex)". • Device address is displayed such as "Address: Device address". • Received error codes are displayed such as "Decimal[Hex]".

Display Examples of Error Messages

"RHAA035: PLC1: Error has been responded for device write command (Error Code: 2 [02H])"

-
- NOTE**
- Refer to your External Device manual for details on received error codes.
 - Refer to "Display-related errors" in "Maintenance/Troubleshooting Guide" for details on the error messages common to the driver.
-